

Ultra-High Speed All-Optical T Flip-Flop Without Preset and Clear Using Non-Linear Material: a Theoretical Study

**Samir Sahu¹, Radha Raman Pal² and Shantanu Dhar³*

¹Department of Physics and Technophysics, Vidyasagar University, Midnapur – 721102, W. B., India. E-mail: tosamirsahu@gmail.com

²Department of Physics and Technophysics, Vidyasagar University, Midnapur – 721102, W. B., India. E-mail: rrpal@mail.vidyasagar.ac.in

³Department of Physics, Jhargram Raj College, Jhargram – 721507, W. B., India. E-mail: ddhar_hit@rediffmail.com

Received September 12, 2011; accepted November 17, 2011

ABSTRACT

A non-linear material (NLM) based all-optical switching mechanism is exploiting here to realize the all-optical T flip-flop without preset (PR) and clear (CLR). The all-optical switch by a composite slab of linear medium (LM) and non-linear medium is the building block of our proposed flip-flop circuit. As the flip-flops are sequential logic circuits, the present states of outputs are dependent not only on the present inputs but also on the past outputs. In our present scheme the outputs are fed back to the former stages as well as the input stages. The output of the flip-flop and its complement are obtained simultaneously in our scheme.

Keywords: Nonlinear material, All-optical switch, All-optical logic gate, All-optical flip flop.

1. Introduction

With the increment of data traffic day-by-day, there is a requirement to restrict research problems in a particular region to achieve the reliable, faithful and high speed performances in computation [13, 17-18] and communication [7, 16]. In this regard, the limitations [7, 10, 13, 15, 17-18] of electronics are familiar. Signal processing in all-optical domain is essential in future high bit-rate communication and computation to avoid electronics bottleneck. We have to replace electronics with photonics [8, 13-18]. All-optical techniques for processing light wave-computation signals have advanced significantly in last few years. Indeed, intensive research has

produced practical all-optical devices for various arithmetic [7, 10, 17, 19], logic [12-13, 18], algebraic [15] operations. As these types of optical systems require some optical switches, design of all-optical switches is of great interest to the photonics community. Non linear material has established its validity as optical switching devices [5-7, 10, 12-19].

These devices are used to develop various combinational logic circuits [15-16] as well as sequential logic circuits [1, 4, 13-18] by many scientists and technologists. For example, all optical flip-flops are key devices for realizing many functionalities in optical networks, optical computing, especially as all-optical memories for the temporary storage of data. Several optical flip-flops using different techniques have already been proposed [1, 3, 10, 13, 15, 17-18]. An all-optical S-R, clocked S-R, D, J-K and J-K master-slave type flip-flops using non-linear material [1, 4, 10, 13, 18, 20] was also reported. Now, in our present paper we proposed a scheme for all optical implementation of ultra-high speed synchronous T flip-flop without preset and clear using non-linear material as all optical switches. As this all optical flip-flop is purely all-optical in nature, it is very simple as well as very fast. The advantageous side of our scheme is that there are two outputs which are complemented to each other. Also the scheme has capacity of cascading.

2. All-optical switching behaviour of nonlinear material

The phenomenon photorefractivity [5-6, 12, 14, 17-19] of some nonlinear optical material is used in nonlinear all-optical intensity switching mechanism. The photorefractive effect, where the refractive index changes induced by a light field when the crystal is subjected to intense laser radiation, defocusing and scattering of the light, is observed, as a result of an inhomogeneous change in the refractive index. It is also found that these changes still prevail even after the light is switched off, but it could be erased by strong, uniform illumination [5]. The refractive index of some nonlinear materials (NLM) such as carbon disulfide, pure silica, potassium dihydrophosphate (KDP) crystal etc. varies linearly with the intensity of the light incident on it. The refractive index (n) of such isotropic dielectric non-crystalline media can be put into an equation as

$$n = n_0 + n_1 I \quad (1)$$

where n_0 is the linear term, n_1 is the nonlinear correction term and I is the intensity of the incident light beam on the material.

We can implement the switching mechanism with such nonlinear material by taking an interface between two media of which one is a linear material (LM), whose refractive index n_0 is independent of the intensity of light and the other is aforesaid NLM. A laser beam, highly intense polarized light, preferably pulse laser of intensity I_1 , is allowed to incident on the interface from linear to nonlinear part in a particular direction XO (incidence angle θ_1) as depicted in Figure 1. The refracted beam from the NLM follows the path OZ (angle of refraction θ_2). But when another higher intense laser beam of intensity I_2 ($I_2 > I_1$) is made to incident along XO, after refraction from the NLM the light passes through OY direction. The deviation of refractive angle for different incident light intensity I_1 and I_2 is $\angle ZOY = \Delta\theta_2$. Thus

the combination of LM and NLM may act nicely as a directional all-optical switch. This is the unit block of our proposed T flip-flop circuit.

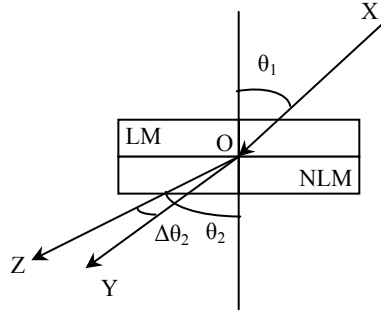

Figure 1. Intensity switching of optical nonlinear material

In the expression of refractive index in eqn. (1), n_0 is linear term and n_1 is the nonlinear correction term. For carbon disulfide [6, 13, 18-19] (CS_2) $n_0 = 1.63$, $n_1 = 514 \times 10^{-20} \text{ m}^2/\text{W}$. and for fused silicon dioxide [6, 13, 18-19] (SiO_2) $n_0 = 1.458$, $n_1 = 2.7 \times 10^{-20} \text{ m}^2/\text{W}$. If we use CS_2 and SiO_2 as nonlinear materials and the pulse laser of intensity $I = 2 \times 10^{18} \text{ W/m}^2$ as a source, we can estimate the deviations of light in two cases as given in Table 1.

Table 1. Estimation of the deviation of pulsed laser light when passing through carbon disulfide (CS_2) and silicon dioxide (SiO_2).

Material	Angle of incidence (θ_1)	Incident light intensity	n	Angle of refraction (θ_2)	Deviation ($\Delta\theta_2 = \theta'_2 - \theta''_2$)
carbon disulfide (CS_2)	45 deg	$I=2 \times 10^{18} \text{ W/m}^2$	11.91	3.404 deg = θ'_2	1.578 deg
	45 deg	2I	22.19	1.827 deg = θ''_2	
silicon di-oxide (SiO_2)	45 deg	$I=2 \times 10^{18} \text{ W/m}^2$	1.512	27.883deg = θ'_2	1.041 deg
	45 deg	2I	1.566	27.842deg = θ''_2	

3. All-optical NOT gate and AND gate

The logic gates [6-7, 10, 13-15, 18-19] are implemented in optics using NLM by taking the presence of light signal (in a range of intensity level) as 1 and the absence of it as 0. The detectors, which can response as 1 in a along range of light signal intensity, will detect the output beam after refraction at the output. The implementation of such logic gates can be done by using some femtosecond laser

pulses and 1-mm-thick potassium dihydrophosphate (KH_2PO_4 (KDP) crystal at the peak intensity of $0.6 \text{ TW}/\text{cm}^2$ and duration of 60 fs [13, 16, 18-19].

3.1 All optical NOT gate: To implement an all optical NOT gate using non-linear material a constant intensity pulse laser source (CILS) is used as shown in Figure 2. CILS is also called probe beam. Here P_1 is taken as input beam. A detector is placed at P_2 will detect the output beam after refraction. If P_1 is absent, the light will follow a path OP_2 and will be detected by the detector due to presence of CILS. But if P_1 is present, after refraction, the light will follow a path other than OP_2 , may be OP_3 , and the detector will not detect any light signal. Thus the system acts as optical NOT gate.

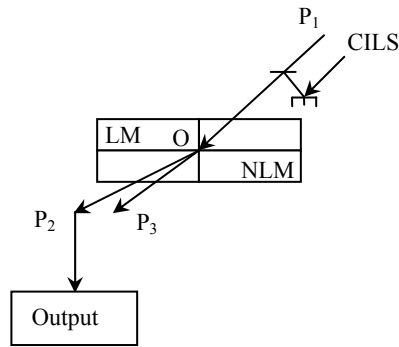

Figure 2. All-optical NOT gate

3.2 All Optical AND gate: The all-optical AND gate using two inputs and three inputs are shown in Figure 3. The two inputs all-optical AND gate using NLM is shown in Figure 3(a).

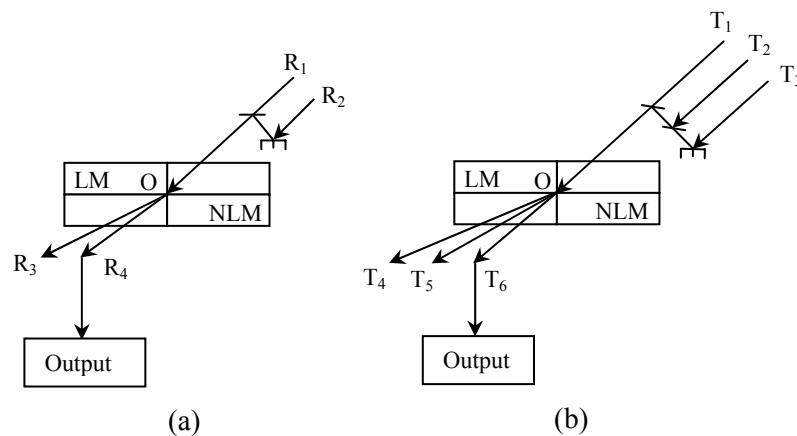

Figure 3. All-optical AND gate using NLM. (a) two-input AND gate. (b) three-input AND gate

Here R_1 and R_2 are two input channels. A detector placed at R_4 gives the output. Now when both the channels carry light signal, the light beam after refraction will be detected by the detector at R_4 , unless not.

The three inputs all-optical AND gate using NLM is shown in Figure 3(b). Here T_1 , T_2 and T_3 are three input channels. A detector placed at T_6 gives the output. Now when all the channels carry light signal, the light beam after refraction will be detected by the detector at T_6 , unless not.

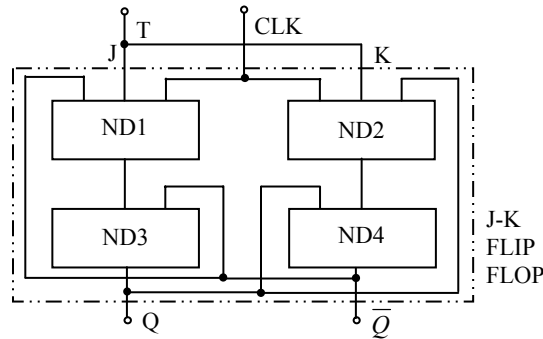

Figure 4. Electronically addressed T flip-flop

4. Conventional electronic flip-flops

A flip-flop is a device with two stable states. It remains in one of these states until triggered into other. Figure 4 shows the block diagram of conventional electronic T flip-flop [1, 9-11]. The T flip-flop is obtained from a J-K flip-flop [1, 9, 18, 11] if both inputs are coupled together as in Figure 4. The ND1...ND4 are electronically addressed NAND gates. The modified truth tables for a J-K flip-flop [18] and T flip-flop are given below in Table 2 and 3 respectively.

Table 2. Truth table of Clocked J-K flip-flop

Inputs			Outputs		State
CLK1=CLK2	J	K	Q_{n+1}	\bar{Q}_{n+1}	
0	d	d	Q_n	\bar{Q}_n	Previous
1	0	0	Q_n	\bar{Q}_n	Previous
1	1	0	1	0	Set
1	0	1	0	1	Reset
1	1	1	\bar{Q}_n	Q_n	Toggle

d = whatever may be the input

5. All Optical T Flip-Flop Without Preset and Clear

Now we talk about the fundamental design of the all-optical circuit of the T flip-flop as shown in Figure 5. Here T is the input and Q and \overline{Q} are the final output states of the T Flip-Flop. There are four all-optical AND gates (AG1, AG2, AG3 and AG4) and four all-optical NOT gates (NG1, NG2, NG3 and NG4) in our proposed circuit. Among the four AND gates first two AND gates (AG1 and AG2) are three-inputs AND gates and the rests (AG3 and AG4) are two-inputs AND gates. The presence of the light is supposed as '1' and the absence is supposed as '0'. The input T is the constant intensity light source, preferably pulse laser. The T is connected to one of the three inputs of both the AG1 (J) and AG2 (K) respectively. CLK1 and CLK2, clock pulses in the form of pulse laser of similar intensity as J and K, are and feed backs from \overline{Q} and Q are the other inputs of the two rest inputs of AG1 and AG2 respectively. F_1 and F_2 , the respective outputs of AG1 and AG2, are used as the input of two corresponding NOT gates, NG1 and NG2. Two constant intensity light sources CILS1 and CILS2 preferably pulse laser sources of similar intensity level are fed in the input channels of both the NOT gates NG1 and NG2 respectively as probe beams. The output beams from NG1 (D_3) and NG2 (D_4) are now used as one of the inputs of AG3 and AG4 respectively. \overline{Q} and Q the final output beams are fed to AG3 and AG4 respectively just like AG1 and AG2. F_5 and F_6 are the outputs of AG3 and AG4 respectively. Now F_5 beam is allowed to incident as the input beam of NG3. A probe beam CILS3 in the form of pulse laser is used for the proper action of NG3. Similarly, F_6 beam is allowed to incident as the input beam along with a probe beam (CILS4) of NOT gate NG4. The output D_7 from NG3 is taken to be the final Q and output D_8 from NG4 is taken to be the final \overline{Q} of the all-optical T flip-flop.

Let us realize the operation of the clocked T flip-flop

When the clock pulse beams are inactive i.e. $CLK1 = CLK2 = 0$, both the outputs F_1 and F_2 of AG1 and AG2 respectively, give 0 whatever may be the other inputs of the flip-flop. As $F_1 = F_2 = 0$ the light will be present at D_3 and D_4 position due to the probe beams CILS1 and CILS2 respectively. This light is fed in the channel of the inputs of the AND gates AG3 and AG4. Here two possibilities may arise. Possibility 1; if $\overline{Q}_n = 0$ and $Q_n = 1$, then $F_5 = 0$ and $F_6 = 1$ consequently $D_7 = 1$ and $D_8 = 0$, i.e. the Q_{n+1} th state preserve the Q_n th state and \overline{Q}_{n+1} th state also preserve the \overline{Q}_n th state. Possibility 2; if $\overline{Q}_n = 1$ and $Q_n = 0$, then F_5 gives 1 and F_6 gives 0 consequently D_7 gives 0 and D_8 gives 1, again the Q_{n+1} th state and \overline{Q}_{n+1} th state follow the Q_n th state and \overline{Q}_n th state respectively.

When $CLK1 = CLK2 = 1$ (i.e. active part of the clock pulse beam), two circumstances may occur. They are as follow:

Let T is inactive (i.e. $J = K = 0$). Then there will be no light at both the output terminals F_1 (from AG1) and F_2 (from AG2) irrespective of the other two

inputs of AG1 and AG2. The outputs Q and \bar{Q} are latched to their previous state very similar to the aforesaid condition ($CLK1 = CLK2 = 0$; J, K whatever may be).

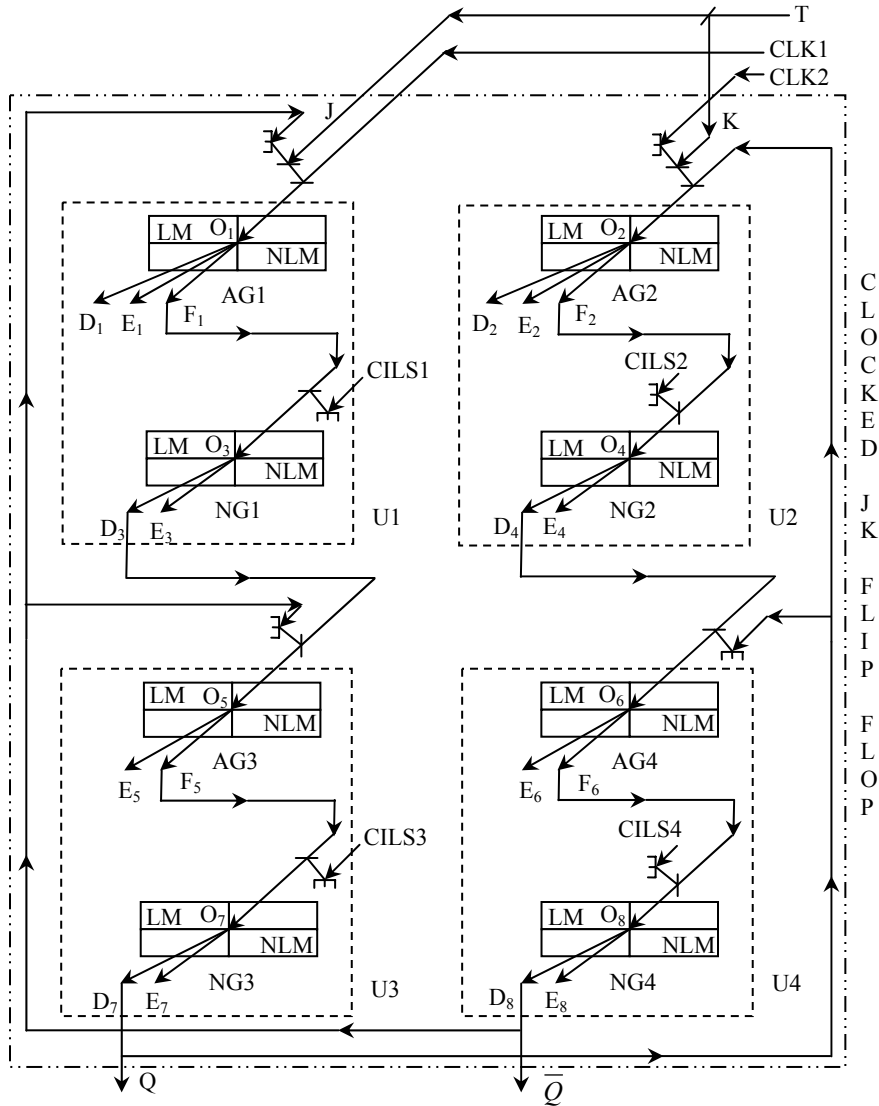

Figure 5. All-Optical T Flip-Flop without Preset and Clear

Now, we consider the other possible input $T = 1$. That means J and K both become active. Here two cases may arise, case 1; if $\bar{Q}_n = 1$ and $Q_n = 0$, then $F_1 = 1$ and $F_2 = 0$ therefore, $D_3 = 0$ and $D_4 = 1$. As the output of AND gate gives 0 when

any one input is inactive irrespective of the other inputs, there is no light signal present at F_5 (i.e. $F_5 = 0$). As a result the output of NG3 will be 1, i.e. $D_7 = Q_{n+1} = 1$. Now, AG4 has two inputs, one is Q and the other is D_4 and both the input terminals have light signal. Since, $Q = D_4 = 1$, light will follow the path O_6F_6 (i.e. $F_6 = 1$). Then D_8 or \overline{Q}_{n+1} will become 0 as both the input beams F_6 and probe beam CILS4 of NG4 are present. Case 2; if $\overline{Q}_n = 0$ and $Q_n = 1$, $F_1 = 0$ and $F_2 = 1$, as a result D_3 gives 1 and D_4 gives 0. Since, AG4 is an AND gate and $D_4 = 0$ is one input of it, the light will appear at E_6 terminal. So, $F_6 = 0$ and hence $D_8 = 1$ i.e. $\overline{Q}_{n+1} = 1$. Now, AG3 has inputs $D_3 = 1$ and $\overline{Q} = 1$. $F_5 = 1$ and outcome of this is $D_7 = 0$. That means Q_{n+1} state is now become 0. Thus here the circuit always changes state and complement to previous output i.e. if $Q_n = 1$ it switches to $Q_{n+1} = 0$ and vice versa. The characteristic equation [8] is shown in Figure 6 and the truth table is shown in Table 3.

			T
		0	1
Q	0	1	1
	1	1	0

$$Q_{n+1} = T \overline{Q}_n + \overline{T} Q_n \text{ (When CLK=1)}$$

Figure 6. Characteristic equation

In our scheme we use all optical AND and NOT gate in designing the all optical T flip flop. In our design the light beam which is fed back is coming from the output of a NOT gate. Again the concept used here to design the all optical NOT gate has an advantage. When ever the output of a NOT gate is assumed to be at ‘1’ state, the source of that ‘1’ state is a constant intensity pulse laser source (CILS) used as probe beam. So in each feedback arrangement described in our scheme similar intense light beam is fed back. In this way the reduction of intensity by using beam splitter will not affect the non-linear response of the device. The light sources are so chosen that each input beam intensity is in the range of intensity which is detected as ‘1’ by the detector.

In T flip-flop due to feed back connection a problem may arise. If the active states of the clock pulses CLK1 and CLK2 are so large that they remain 1 (while $T = 1$) after the output has been complemented, the action of complementation of output will repeat. Then the problem is same as electronic circuits and it is called race-around [3, 8, 10] problem. Therefore the duration of clock pulse should be chosen critically.

Table 3. Truth table of Clocked T flip-flop

Inputs			Outputs		State
CLK1	Q_n	T	Q_{n+1}	\overline{Q}_{n+1}	
CLK2					
0	d	d	Q_n	\overline{Q}_n	Previous
1	0	0	0	1	Previous
1	1	0	1	0	
1	0	1	1	0	Toggle
1	1	1	0	1	

d = whatever may be the input

6. Conclusion

The proposed technique of all optical implementation of T flip-flop is very fast (above THz) [7-8, 13, 16-19] as it is fully all-optical. The light signals which are severally used and the feedback light signals from the outputs are made by mirrors and beam splitters to make the circuits simple. Another important feature is that all-optical temporary data storage memories and counters may be developed by cascading the flip-flops. All though the output states of the flip flop are assumed arbitrary before the application of light pulses which can be definite by introducing preset (PR) and clear (CLR) inputs to the proposed flip flop. Proper findings of non-linear material may be a significant issue here. Essentially inputs and constant intensity light source should be chosen properly to run the system accurately. The clock pulse signal should also be selected suitably.

Acknowledgements

The authors want to acknowledge Professor Sourangshu Mukhopadhyay of the University of Burdwan for his valuable suggestions.

REFERENCES

1. K. Datta, S. Munshi, Optical implementation of flip-flops using single-LCD panel, *Optical & Laser Technology*, 39:9(2007), 2321-2329.
2. Sinha, H. Bhowmik, P. Kuila, and S. Mukhopadhyay, A new method of controlling the power of a gaussian optical pulse through electro-optic modulator and non-linear wave guide for generation of soliton, *Optical Engineering*, 44:6(2005), 065003-10.
3. H. Chen, S. Matsuo, K. Nozaki, A. Shinya, T. Sato, Y. Kawaguchi, H. Sumikura, M. Notomi, All-optical memory based on injection-locking bistability in photonic crystal lasers, *Opt Express*, 19:4(2011), 3387-3395.

4. H. Chen, S. Matsuo, K. Nozaki, A. Shinya, T. Sato, Y. Kawaguchi, H. Sumikura, M. Notomi, All-optical memory based on injection-locking bistability in photonic crystal lasers, *Opt Express*, 19:4(2011), 3387-3395.
5. Arivouli, Fundamentals of optical nonlinear materials, *Pramana*, 57:5,6(2001), 871-883.
6. Samanta, S. Mukhopadhyay, A method of maintaining the intensity level of a polarization encoded light signal, *Journal of Physical Science*, 11(2007), 87-91.
7. K. R. Choudhury and S. Mukhopadhyay, Binary optical arithmetic operation scheme with tree architecture by proper accommodation of optical nonlinear materials, *Optical Engineering*, 43:1(2004), 132-137.
8. Li Pei-Li, Huang De-Xiu, Zhang Xin-Liang and Wang Yang, Single-SOA-Based Ultrahigh-Speed All-Optical Half Subtractor with PolSK Modulated Signals, *Chinese Physics Letters*, 25:5(2008), 1705-1712.
9. M. Morris Mano, *Digital Logic and Computer Design*, Prentice-Hall of India Private Limited, New Delhi, 2000.
10. N. Pahari, S. Mukhopadhyay, An all optical R-S flip-flop by optical non-linear material, *J. of Opt.*, 34:3(2005), 108-114.
11. R. P. Jain, *Modern Digital Electronic*, Tata McGraw-Hill India, N. Delhi, 2007.
12. S. D. Smith, I. Janossy, H. A. Mackenzi, J.G. H. Mathew, J. J. E. Reid, M. R. Taghizadeh, F. A. P. Tooley and A. C. Walker, Nonlinear optical circuit elements, logic gates for optical computers: the first digital optical circuits, *Optical Engineering*, 24:4(1985), 569-573.
13. S. Dhar and S. Sahu, All-optical implementation of S-R, clocked S-R and D flip-flops using nonlinear material, *Optical Engineering*, 47:6(2008), 065401-7.
14. S. Dutta and S. Mukhopadhyay, An all optical approach of frequency encoded NOT based Latch using semiconductor optical amplifier, *Journal of optics*, 39:1(2010), 35-41.
15. S. K. Garai and S. Mukhopadhyay, All-optical frequency encoded binary half subtractor using periodically poled lithium niobate waveguide and reflecting semiconductor optical amplifier, *Optics and Photonics Lett*, 3:1(2010), 15-22.
16. S. Mironov, V. Lozhkarev, V. Ginzburg and E. Khazanov, High-efficiency second-harmonic generation of superintense ultrashort laser pulses, *Applied Optics*, 48(2009), 2051-2059.
17. S. Mukhopadhyay, A. K Datta, A Basuray, Optical computing: Researches in this decade, *Optics*, 17:4(1988), 94-100.
18. Sahu and S. Dhar, Implementation of clocked J-K, T and J-K Master Slave flip-flops with nonlinear material in All-optical Domain, *Opt. Engineering*, 48:7(2009), 075401-8.
19. Sahu, R. R. Pal and S. Dhar, A Novel Method of Implementing Nonlinear Material Based All-Optical Binary Half Subtractor and Full Subtractor System, *J. of Electron Devices*, 10(2011) 493-498.
20. Chattopadhyay, All-optical clocked delay flip-flop using a single terahertz optical asymmetric demultiplexer-based switch: a theoretical study, *Appl. Opt.*, 49(2010) 5226-5235.