

Making Sense About Dipole Moments

Tridib Tripathy and B. R. De***

* Department of Chemistry, Midnapur College, Midnapur,
Paschim Medinipur

** Department of Chemistry, Vidyasagar University, Midnapur,
Paschim Medinipur

Received November 17, 2008; accepted November 30, 2008

ABSTRACT

Although the method of dipole moments has recently been left somewhat in the shadow of other rapidly developing methods it is still an important tool for structural investigations in organic chemistry. It is used for determination of the type of a chemical bond (polar or covalent) molecular geometry (isomerism, valence angles etc.) mutual effects of atoms and groups (mesomeric electron shift, ortho effect, etc.) properties of complexes and so on. It also reflects the electron density distribution in molecule in different states.

1. Introduction

A diatomic molecule such as A_2 has a covalent bond, which contains two electrons of opposite spin. Two A atoms, each with a single electron, combine to form this bond. Since each A atom contributes one electron, a neutral A_2 atom must have an electron density equal to unity. The two electrons in the covalent bond are shared equally, the electron density is the same at each atom, and the molecule is non-polar. But in a diatomic molecule like A-B where B is more electronegative than A the two bonding electrons are not shared equally. The electron density at A is less than unity where as the electron density at B is greater. In this molecule there exists a region which is relatively + ve and a region that is relatively - ve; such a molecule is polar. So in the molecule containing atoms of different electronegativity the electron density is higher near more electronegative atoms and lower near the less electronegative atoms. While the molecule is as a whole neutral, there is a point within the molecule about which the + ve charge centers and a point about which the negative charge centers. If these two centers do not coincide, the molecule will have electric dipole moment.

The electric moment is defined as $\mu = e \times d$ where e is the magnitude of charge at either end of the dipole, and d is the distance between the centers of + ve and - ve charge. The dipole moment is a vector quantity associated with magnitude and direction. The dipole moment is expressed by $\text{+} \longrightarrow \text{-}$ symbol as shown in Figure 1.

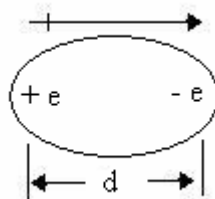

Figure 1. The direction of dipole moment

Dipole moments have a dimension of charge \times distance (esu – cm). Since the charge is of the order of 1×10^{-10} esu and the distances are of the order of 1 \AA (10^{-8} cm) the order of magnitude for dipole moments is $\mu = 10^{-10} \times 10^{-8}$ esu-cm = 10^{-18} esu-cm. Dipole moment is expressed in Debye defined as 1 Debye (D) = 10^{-18} esu-cm. A molecule with one positive and one negative charge separated by 1 \AA would have a dipole moment of 4.80 D (charge of one electron = 4.80×10^{-10} esu). In SI system the unit of dipole moment is Cm (coulomb \times meter) where, $1\text{D} = 3.334 \times 10^{-30}$ Cm

2. Dipole Moments of Bonds and Groups and Vector Addition

A bond connecting two atoms differing in electro negativity is associated with an electrical moment called bond moment. The dipole moment of a molecule is the vectorial sum of the individual bond moments present in it. Groups such as alkyl groups, $-\text{NH}_2$, $-\text{NO}_2$, $-\text{OH}$ etc. have definite moments called group moments.

The dipole moments of polyatomic molecules depend on the nature of the atoms and on their arrangement. The dipole moment of a molecule is the vector sum of the dipole moments of the bonds and is calculated according to the rule of vector addition (Figure 2). If the interactions between atoms and groups are not strong, the dipole moments of the bonds are additive and each bond can be ascribed a certain dipole moment which is approximately the same in various compounds

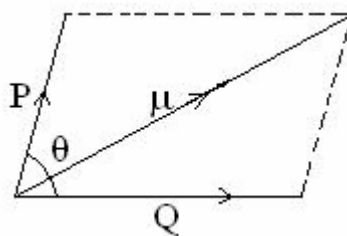

Figure 2. Vector addition of the dipole moments

Two vectors are added using the parallelogram of vectors. If two bonds with the dipole moments P and Q are at an angle θ the total dipole moment is given by

$$\mu^2 = P^2 + Q^2 + 2PQ \cos \theta \quad \dots\dots\dots (1)$$

For instance two identical bonds with the opposite directions ($\theta = 180^\circ$) have $\mu = 0$. For identical bonds ($P=Q$) equation (1) yields

$$\mu^2 = 2P^2(1 + \cos \theta) \quad \dots\dots\dots (2)$$

The dipole moment is computed on the basis of the geometry of the molecule and the bond moments. Thus one could estimate the dipole moment of methyl alcohol by the following way

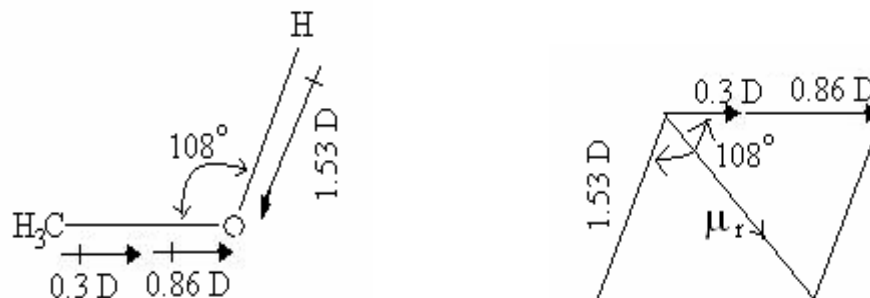

Figure 3. Calculation of the dipole moment of CH_3OH using law of parallelogram

Using the law of cosine for the parallelogram, one has

$$\begin{aligned}\mu_{\text{resultant}} &= \sqrt{(0.3 + 0.86)^2 + 1.53^2 + (2 \times 1.16 \times 1.53) \cos 108^\circ} \\ &= \sqrt{1.35 + 2.34 + 5.38(-0.309)} \\ &= \sqrt{2.03} = 1.64\text{D}\end{aligned}$$

$$\mu_{\text{observed}} = 1.67\text{ D}$$

The approximate moment of *ortho*, *meta* or *para* di substituted benzene also can be obtained by vector addition of the moments of the respective mono substituted compounds. If μ_1 and μ_2 are the moments associated with the substituents of the mono substituted benzenes, their vector addition can be made according to the law of cosines, where θ is 60° for *ortho* isomer, 120° for *meta* isomer, 180° for *para* isomer. The calculation process is shown in Figure 4.

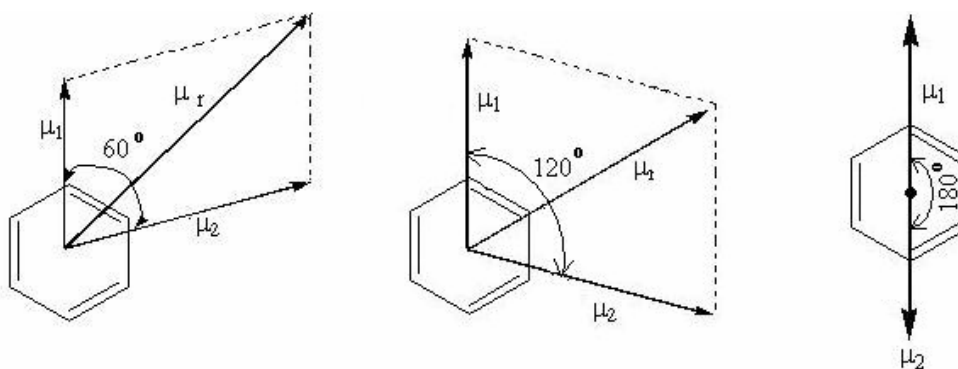

Figure 4. Calculation of the dipole moments of substituted benzenes.

$$\mu_r = \sqrt{\mu_1^2 + \mu_2^2 + 2\mu_1\mu_2 \cos \theta}$$

$$\text{For } \textit{ortho} \text{ isomer; } \mu_r = \sqrt{\mu_1^2 + \mu_2^2 + \mu_1\mu_2}$$

$$\text{For } \textit{meta} \text{ isomer; } \mu_r = \sqrt{\mu_1^2 + \mu_2^2 - \mu_1\mu_2}$$

$$\text{For } \textit{para} \text{ isomer; } \mu_r = \sqrt{\mu_2 - \mu_1}$$

As an illustration, the values calculated from these equations for the chloro toluene are in satisfactory agreement with the observed values (Figure 5.)

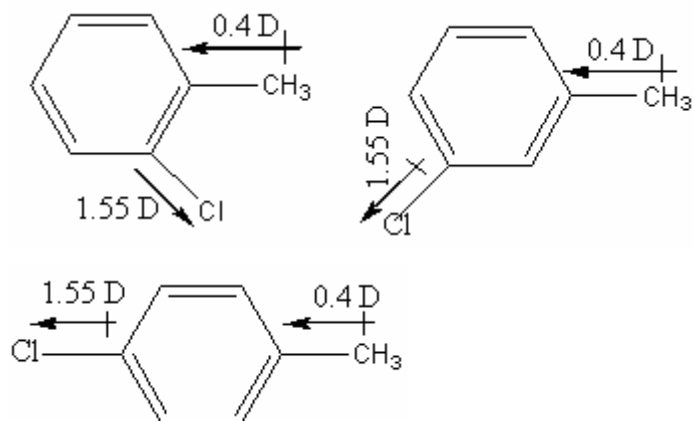

$$\mu_r = 1.39 \text{ D (cal.)}$$

$$\mu_r = 1.79 \text{ D (cal.)}$$

$$\mu_r = 1.95 \text{ D (cal.)}$$

$$\mu_r = 1.3 \text{ D (obs.)}$$

$$\mu_r = 1.78 \text{ D (obs.)}$$

$$\mu_r = 1.90 \text{ D (obs.)}$$

Figure 5. Calculation of the dipole moments of substituted chloro toluenes using law of parallelogram

Branch and Calvin have made similar calculations for a number of disubstituted benzenes and their results are listed in the Table 1.

Table 1. Calculated and observed moments (in Debyes) of some disubstituted benzenes

Moment of C ₆ H ₅ X		Moment of C ₆ H ₅ Y		Moment of C ₆ H ₄ XY					
Values for X		Values for Y		Ortho		Meta		Para	
X	value	Y	value	Obs.	Calc.	Obs.	Calc.	Obs.	Calc.
-CH ₃	0.4	-CH ₃	0.4	0.5	0.7	0.4	0.4	0	0
-F	1.43	-F	1.43	2.4	2.48	-	-	-	-
-Cl	1.55	-Cl	1.55	2.3	2.67	1.48	1.55	0	0
-Br	1.52	-Br	1.52	2.0	2.63	1.5	1.52	0	0
-I	1.3	-I	1.3	1.7	2.25	1.3	1.30	0	0
-NO ₂	3.95	-NO ₂	3.95	6.0	6.83	3.79	3.95	0	0
-CH ₃	0.4	-Cl	1.55	1.3	1.39	1.78	1.79	1.90	1.95
-CH ₃	0.4	-NO ₂	3.95	3.66	3.76	4.17	4.16	4.4	4.35
-Cl	1.55	-NO ₂	3.95	4.3	4.91	3.4	3.44	2.5	2.4

The discrepancies between calculated and observed values are largest for large substituents in *ortho* position, which spread apart due to steric repulsion causing the actual angle to be wider than the normal 60° . For example, in *ortho*-dibromo benzene the two bromine are moved out of ring by an angles of 15° thus increasing θ , where as they remain in the ring plane in the *para* isomer.

The above procedure must be modified when the group moment of the substituted benzene is not in the plane of the ring. For illustration, the angle between the resultant dipole moment of aniline and the axis of maximum polarization is about 70° (Figure 6) Since the axis of maximum polarizability lies in the plane of the benzene ring, this means that the N-H bonds are at some wide angle to the ring.

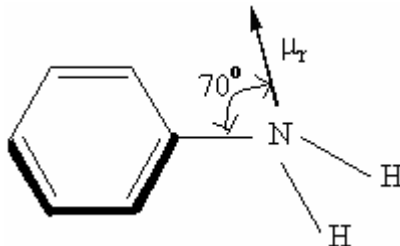

Figure 6.

The dipole moment of such compounds, where the group is not coplanar with the ring, may be closely estimated by use of the following equation.

$$\mu_r^2 = \mu_1^2 + \mu_2^2 + 2\mu_1\mu_2 \cos\phi \cos c_1 \cos c_2 \quad \dots\dots(3)$$

where, μ_r = Resultant moment of the disubstituted benzene, μ_1, μ_2 = Moments of the respective mono substituted benzenes. ϕ = Angle between axes of rotation of the groups in the disubstituted benzene (180° for the *para* isomer, 120° for the *meta* isomer and 60° for the *ortho* isomer) c_1, c_2 = Angles which the group moments make with their axes of rotation.

3. Molecular Moments

We assign to each bond a bond moment and the dipole moment of the entire molecule is just the vectorial sum of these individual bond moments.

* Symmetrical diatomic molecules of A_2 type such as hydrogen, bromine and nitrogen do not have a dipole moment where as unsymmetrical diatomic molecules of the type AB do.

H-H	Br-Br	$N \equiv N$
$\mu = 0D$	$\mu = 0D$	$\mu = 0D$
H-F	H-Cl	H-I
$\mu = 1.75D$	$\mu = 1.03D$	$\mu = 0.38D$

* Perfectly tetrahedral molecules of the type AB_4 will have zero dipole moment e.g., carbon tetrachloride has four polar C-Cl bonds, yet these are tetrahedrally arranged and their vectorial sum is zero. The explanation comes in the following way;

A perfectly tetrahedral molecule CA_4 has the symmetrical tetrahedral structure with the C-atom at the centre and the four identical valences making an angle of $109^{\circ}28'$ with each other. The center of symmetry is at the C-atom. The $-CA_3$ group has a regular pyramidal configuration with C-atom at its apex and three A's at the base. The resultant moment of the three C-A bonds will be directed along a line from the center of the base towards the apex and opposite to the direction of the fourth C-A bond moment. Using X for bond moments, the resultant moment of the $-CA_3$ group is given by

$$\begin{aligned} X_{CA_3} &= 3X_{CA} \cos(180^{\circ} - 109^{\circ}28') \\ &= 3X_{CA} \cos 70^{\circ}32' \\ &= 3X_{CA} \times 1/3 = X_{CA} \end{aligned}$$

Thus the group moment of CA_3 is same as that of the C-A bond but is directed in the opposite directions so cancel each other (Figure 7).

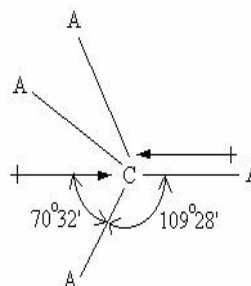

Figure 7.

CH_4 and CCl_4 have zero dipole moment. The dipole moments of $CHCl_3$, CH_2Cl_2 , CH_3Cl result from the fact that chlorine forms the negative end of the dipole (Figure 8)

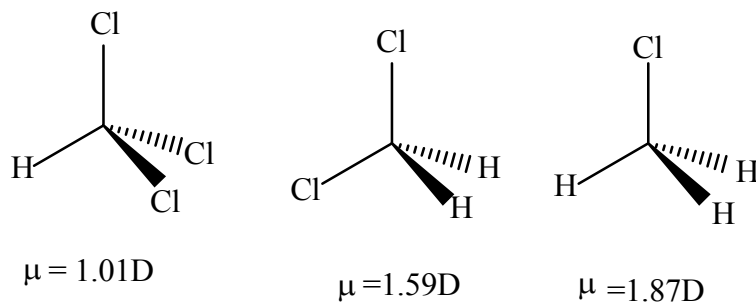
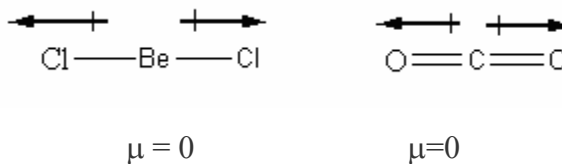

Figure 8. Dipole moments of different substituted chloromethanes

* In practice it is the molecular moment that is obtained experimentally and the magnitude of this moment frequently provides information concerning molecular structure. Following are the example

a) Perfectly linear molecules of the type AB_2 should have zero dipole moment. Since beryllium chloride and CO_2 exhibit zero dipole moment, a linear structure is assigned to these compounds.



b) Water, on the other hand, does have dipole moment and can not have linear structure.

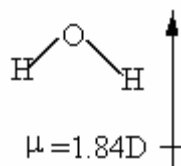

c) Completely planar molecules of the type AB_3 have zero dipole moment because of the following reason.

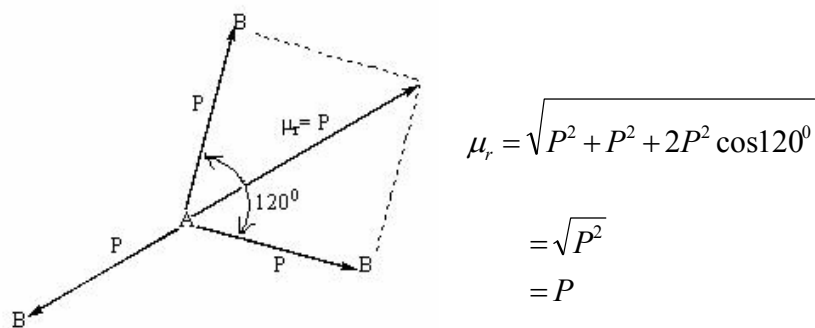

Figure 9. Calculation of the dipole moment of the planar AB_3 molecule

The resultant value (μ_r) of two A-B bond moments (P) is equal in magnitude but opposite in direction to that of bond moment (P) of third A-B bond, hence cancel each other as shown in Figure 9. For example, as boron trifluoride (BF_3) exhibits no dipole moment, we can deduce that this is planar molecule with bond angle equal to 120° . Whereas NF_3 , which has a molecular moment, cannot be planar (Figure 10.)

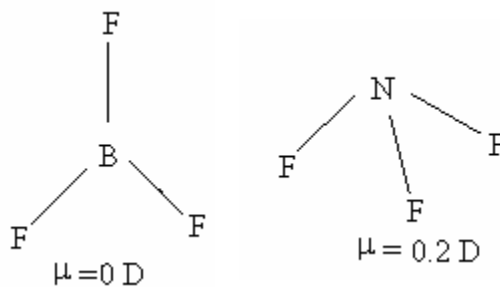
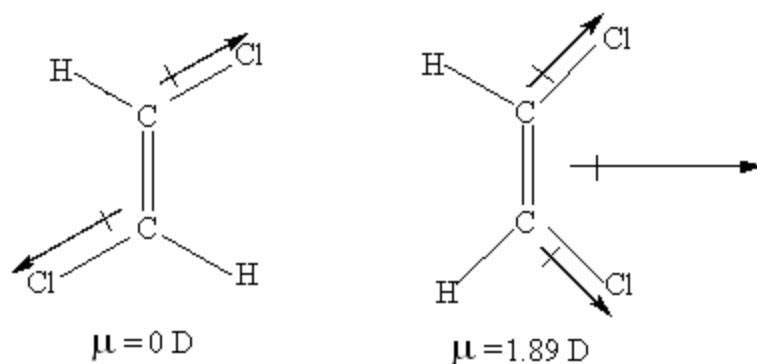

Figure 10. Structure of BF_3 and NF_3 molecules

d) Compounds such as *cis* and *trans* 1,2-dichloro ethene can be characterized by the difference in their molecular moments (Figure 11).

Figure 11. Structure of *cis* and *trans* 1,2-dichloro ethylene

4. The Direction of The C-H Bond Moment

It is not yet certain whether the C-H bond moment is directed towards hydrogen or towards carbon.

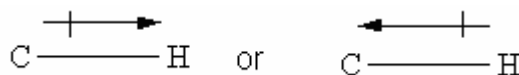

The direction of C-H bond moment does not depend only upon the relative electro negativities of these atoms. Several other factors are important. Carbon for example can use sp^3 hybridized orbital, and these are directed in space as shown in Figure 12.

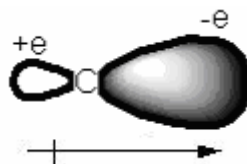
Figure 12. A sp^3 hybrid orbital.

The centre of negative charge for an electron in such an sp^3 hybridized orbital does not occur at the carbon nucleus but at some distance from it. We can associate with an electron in an sp^3 orbital a dipole moment oriented in the same direction as the orbital, and the bond moment for a C-H bond depends to some extent upon this. For this and other reasons we shall assume that the C-H bond moment is directed towards hydrogen.

In proceeding from sp^3 hybridized orbital to an sp^2 orbital the amount of s character increases. Increasing the amount of s character stabilizes the electron. Effectively, the carbon atom appears more electronegative. In addition, an sp^2 orbital is not so well directed in space as an sp^3 orbital. We assume that this bond moment is still directed towards hydrogen (Figure 13), but we naturally expect the magnitude of the C-H bond moment to be smaller when the carbon atom is sp^2 hybridized.

In acetylene, where the carbon atoms are sp hybridized, we continue to assume that the orientation of the C-H bond moment is towards hydrogen. Naturally we expect the magnitude of this moment to be even smaller than the other C-H bond moments.

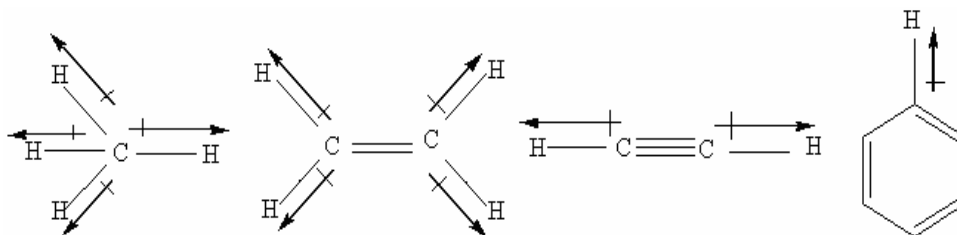

Figure 13. Direction of C-H bond moments

But when a more electronegative atom is attached to the carbon then the C-H bond moment is directed towards carbon (Figure 14).

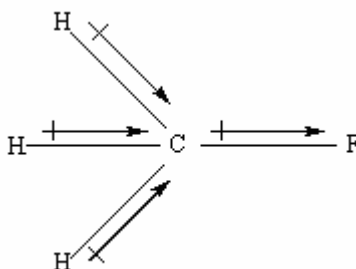

Figure 14.

5. The Effect of Non Bonded Electrons

In the water molecule, where we have four electrons in the two O-H bonds and four non bonded electrons in two sp^3 hybridized orbitals (Figure 15), the dipole moment arises not only from the two bond moments but also from the four electrons in the non-bonded sp^3 hybrid orbitals.

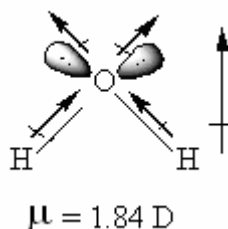
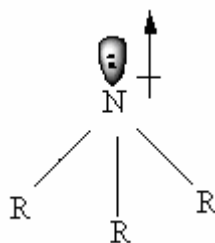

Figure 15. Dipole moments of lone pair of electrons and C-H bond moments of water molecule.

While discussing molecular moments, we must consider the effect of non bonded electrons. If these electrons are in orbital which are directed in space, then such electrons contribute to the total dipole moment of the molecule. This effect is found in nitrogen containing compounds where the electrons in the sp^3

orbital of the nitrogen atom contribute to the molecular moment.



Thus ammonia has an appreciable dipole moment (1.5 D) while the compound NF_3 has a much smaller dipole moment (0.2 D) as shown in Figure 16.

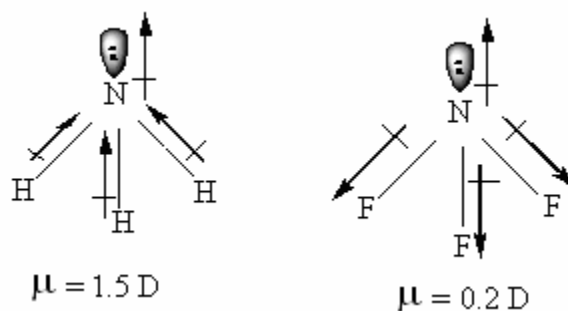
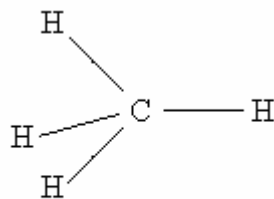

Figure 16. Dipole moments of NH_3 and NF_3 molecules

In ammonia the moment due to the non-bonded electrons operate in the same direction as the N-H bond moments. In NF_3 it is oriented in opposition to the N-F moments. The result is a larger molecular moment for ammonia. Now let us consider two hypothetical situations; if nitrogen were sp^2 hybridized then we would expect a zero dipole moment of both NH_3 and NF_3 , because the two molecules would be flat and symmetrical (like BF_3) and three bond dipoles would cancel out each other. If nitrogen used p orbital for bonding, we would expect NF_3 to have a much larger dipole moment than NH_3 and both NH_3 and NF_3 would be pyramidal. The unshared pair would be in a 2s orbital symmetrical about N, and would provide no dipole to oppose the bond dipoles. Unopposed the large N-F dipoles would give NF_3 a much larger dipole moment than NH_3 .

6. Hybridization and Dipolemoments

The effect of changes in hybridization upon the dipole moment is illustrated by the following examples. Neither CH_4 nor CF_4 has dipole moment. This implies that in methane the vectorial sum of three C-H bond moments must result in a single moment which is equal in magnitude but in opposite direction to the fourth C-H bond moment.



$$\mu = 0$$

In CF_4 this implies that the resultant of three C-F bond moments is equal in magnitude and opposite in direction to the fourth C-F moment.

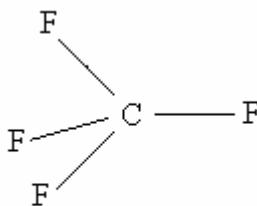

$$\mu = 0$$

If the hybridization and the bond lengths in both CH_3F and CHF_3 were the same, these two molecules would have the same dipole moment.

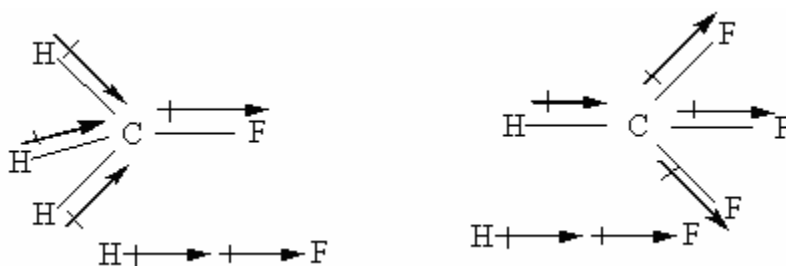

Figure 17. Direction of C-H and C-F bond moments of CH_3F and CHF_3 molecules

For each of these molecules, the dipole moment of entire molecule equals the sum of two collinear bond moments, a C-H and a C-F moment (Figure 17). Therefore the two might be expected to have identical dipole moments, yet this is not the case. The molecule CH_3F has a molecular moment equal to 1.81 D, whereas the CHF_3 moment is only 1.61 D. The hybridization of carbon must be slightly different in the two molecules and a change in the hybridization of one atom affects the hybridization of all the other atoms in the molecule.

7. The Effect of Conformational Changes

In the case of a compound showing conformational isomerism, the dipole moment (μ) of the molecule is related to the dipole moments of the conformers by the following equation (considering two conformers)

$$\mu^2 = n_a \mu_a^2 + n_g \mu_g^2 \quad \dots\dots\dots(4)$$

Where n_a and n_g are the mole fractions of the two conformers anti and gauche forms. The higher dipole moment of ethylene glycol than dichloro ethane is explained on the basis of equation (4) by the following way (Figure 18.) although $\mu_{C-Cl} \approx \mu_{C-OH}$

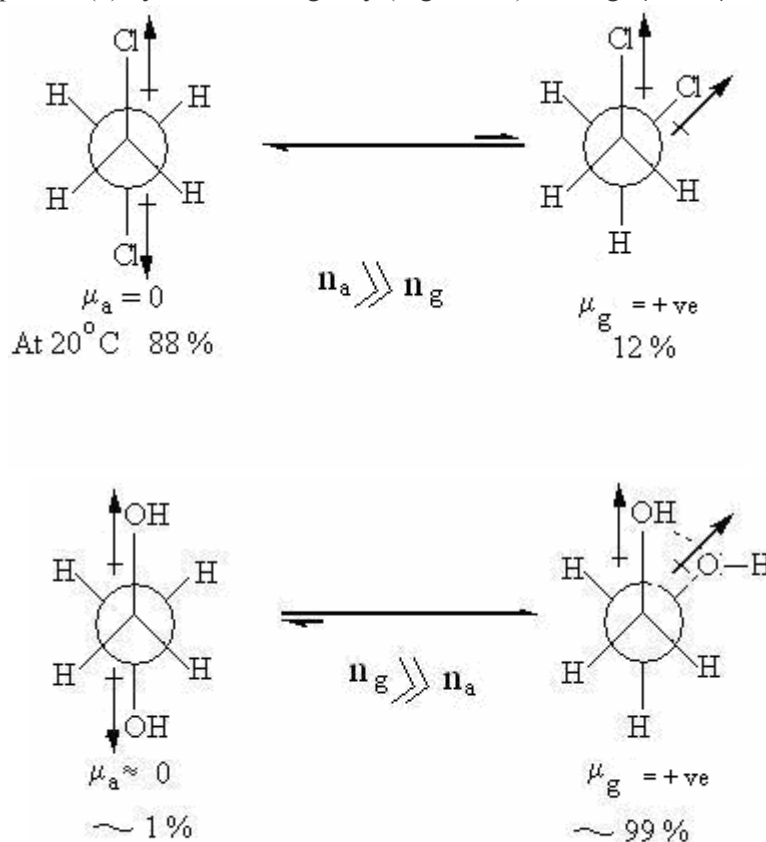

Figure 18. The dipole moments of ethylene glycol and dichloro ethane

The dipole moment of some compounds may be temperature dependent. Dipole moment increases with increasing temperature as the amount of gauche form increases with increasing temperature. The probable explanation comes in the following way.

The free energy change (ΔG) of the following equilibrium;
gauche \rightleftharpoons anti

is $\Delta G = \Delta H - T \Delta S$ where, ΔH and ΔS are the change in enthalpy and entropy of the above equilibrium. Since there are two gauche and one anti conformations ΔS of the process is negative. As the temperature increases $T\Delta S$ term of the above equation increases making ΔG become less negative and K_{eq} becomes smaller as $\Delta G = -RT \ln K_{eq}$ { K_{eq} = equilibrium constant = [anti] / [gauche]}. This means that equilibrium shifts to the left, away from the anti, resulting in a larger concentration of the gauche form

Thus the dipole moment of 1,2-dichloroethane varies with the temperature. This variation is due to the fact that different conformations are possible. At room temperature the compound exists largely in anti form (1) but the 'gauche' form (2) is possible; these are in equilibrium (Figure 19.).

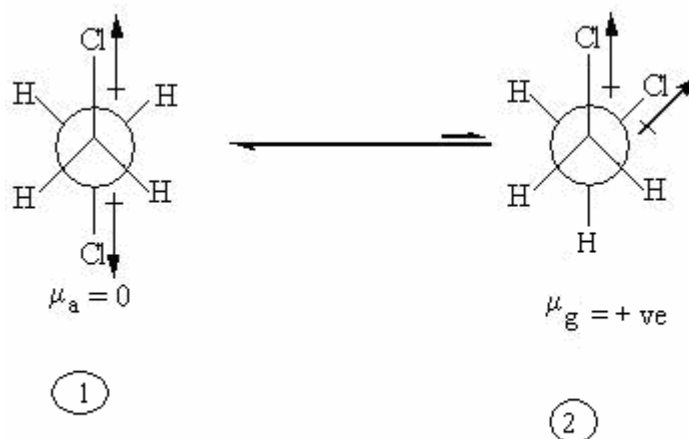

Figure 19. Equilibrium between the gauche and anti form of 1,2-dichloroethane

The *anti* form is expected to show little or no dipole moment, but the *gauche* form should show a significant moment.

The energy of the *anti* form is slightly lower than that of the *gauche* and at moderate temperatures it is the former that predominates. As the temperature is increased the concentration of the *gauche* conformation increases while that of *anti* decreases according to the reason stated above. Thus as the temperature is increased, we expect the observed dipole moment to increase and this is exactly what occurs.

8. Resonance and Dipole Moments

In those cases where resonance interactions are present, the molecular dipole moment can no longer be inferred by the process of addition of bond moments. When resonance effects are present, the usual idea of bond moments breaks down, and we can see why it so happen. If we consider a molecule such as acrolein, with the structure. $\text{H}_2\text{C}=\text{CH}-\text{CHO}$ $\mu = 3.0$ D from the data $\text{H}_2\text{C}=\text{CH}_2$ $\mu = 0$ D and $\text{H}_2\text{C}=\text{O}$ $\mu = 2.3$ D we can attempt to predict the dipole moment of acrolein molecule. If the ideas of localized bond moments and invariance of bond moments were applicable in this case, the predicted moment for acrolein would be the same as the dipole moment of formaldehyde itself. Yet the actual dipole moment of acrolein is larger than the predicted moment. This increase in the dipole moment of acrolein over the predicted value is due to the electrons in the π system. The π electrons, which in ethylene and formaldehyde are localized between two atoms, are able to travel over all four atoms in acrolein. To obtain the dipole moment of acrolein by vectorial addition of bond moments can not possibly give the correct result, for this process does not properly consider the delocalization of the π electrons.

So in order to discuss the dipole moment we must also consider structures such as;

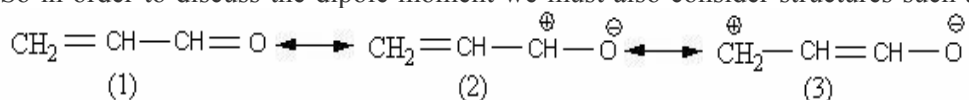

The actual molecule is then a hybrid receiving contributions from the above valence bond structures. The actual dipole moment of the molecule depends upon structures (2) and (3). If we consider ethylene and formaldehyde and attempt to predict the dipole moment of acrolein on this basis, we do not take into account the effect of (3) upon the dipole moment. The effect of this valence bond contributor (3) is to increase both the charge 'e' and the distance 'd' thereby increasing the dipole moment of acrolein.

Similar effects occur with the substituted benzenes. For these molecules, vectorial addition of bond moments and group moments does not adequately consider resonance effects, and attempts to predict the dipole moment of substituted benzenes on the basis of vectorial addition of bond moments generally fail.

Another instance in which π electronic delocalization affects the dipole moment can be seen by considering the sequence.

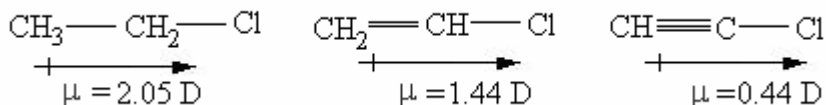

Figure 20.

In proceeding from chloroethane to chloroacetylene the molecular moment decreases (Figure 20.) The hybridization of carbon changes from sp^3 to sp in proceeding along the sequence, and this change is undoubtedly responsible from some of the observed decrease. In addition, there is the possibility of resonance interactions.

In chloroethylene this resonance involves the electrons in the p_z orbital of chlorine. Since the π resonance gives rise to a dipole moment in opposition to the σ moments, such resonance decreases the total dipole moment of the molecule. In chloroacetylene resonance is even more pronounced since both the p_y and p_z orbitals are involved.

9. Hyperconjugation and Dipolemoments of Molecules

The dipole moments of isopropyl and cyclopentyl chlorides are almost the same.

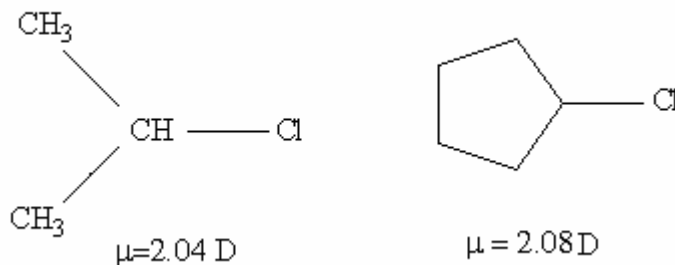

These moments arise from the greater electro negativity of the 'Cl' atom, and are directed along the C–Cl bond. On the basis of induction, one might expect the moment of cyclopropyl chloride to be about the same; however the moment (1.76 D) is 0.3D less. This can be explained in terms of the hyperconjugation (Figure 21.) among such forms as

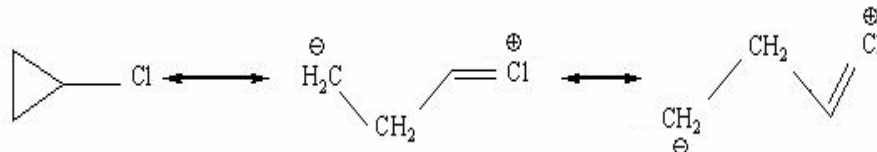
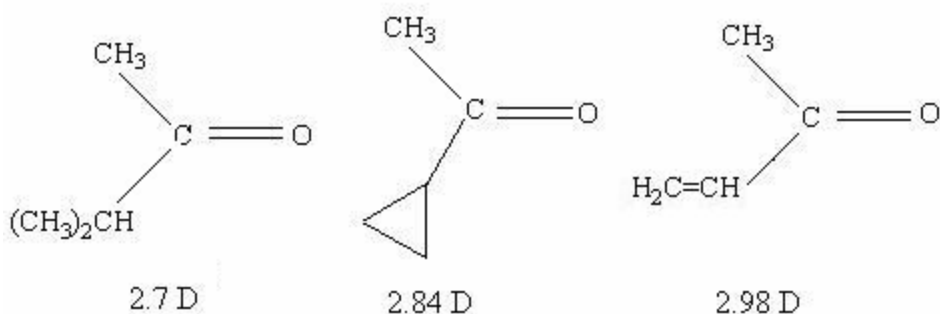

Figure 21. Hyperconjugative structures of cyclopropyl chloride

In the ionic forms, the dipole is directed opposite to that from induction to give a smaller net moment. This type of hyperconjugation, which does not take place to any significant degree with larger rings, is facilitated by the weak C–C bonds of cyclopropyl ring. The C–C–C bond angles are only a little more than 60° , which permits less overlap of the hybrid sp^3 atomic orbitals and consequently the usually strong C–C bonds can not be formed.

The conjugative ability of a three membered ring is less than that of a multiple bond. This is reflected in the dipole moments of the following compounds.



The dipoles of the ionic forms of the resonance hybrid of the vinyl ketone and of the cyclopropyl ketone, for which there are no analogous forms for the isopropyl ketone, are oriented to supplement the induction moments. Thus the intermediate moment of the cyclopropyl ketone indicates that its hyperconjugation is less important than the resonance of the vinyl ketone

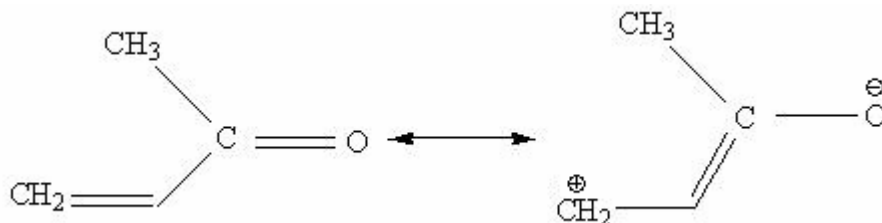

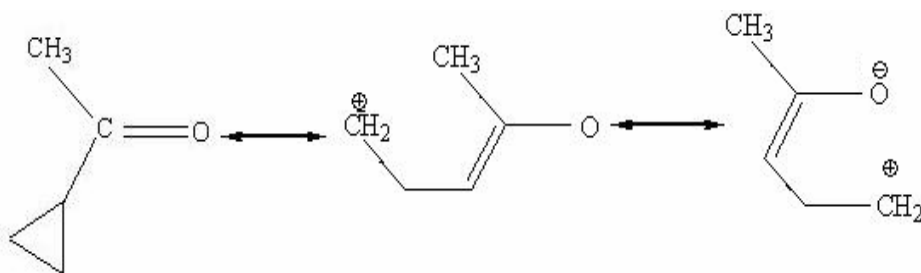

10. Some Representative Examples

The net dipole moment can often be considered as the vector sum of the individual moments of the various bonds. This method will break down if there are interactions between the bonds, which change their electron distributions. Following are some examples.

1. In molecule B the $-\text{NO}_2$ and $-\text{Cl}$ groups are directed in opposite direction for which there is a deduction in dipole moment but in case of molecule A they are not in exactly opposite direction so the two bond moments reinforce each other.

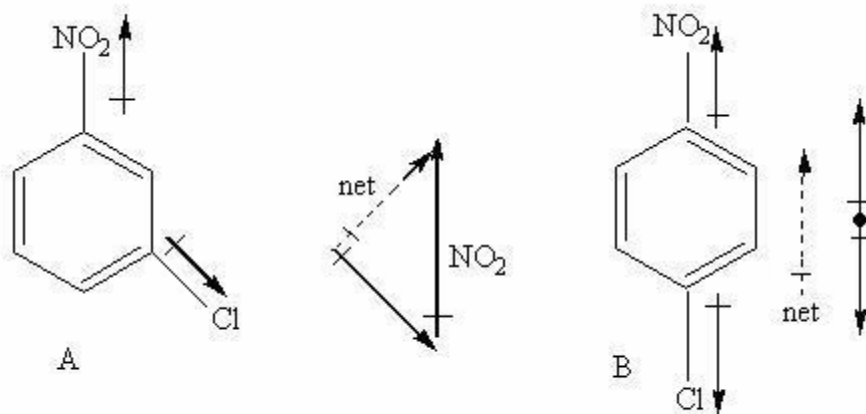

Therefore, $\mu_A > \mu_B$

2. In C the dipole moment of $\text{H}_3\text{C}-\text{C}$ bonds are towards the ring, while those of $\text{C}-\text{NO}_2$ are away. In D the two methyl contributions cancel, but in C they

partially reinforce.

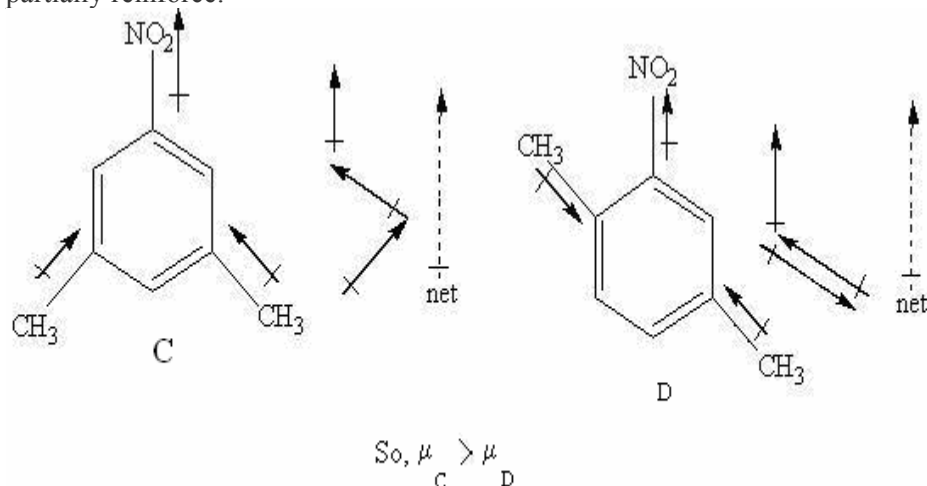

3. The dipole moment of the acetyl groups are oriented approximately along the $>C=O$. In one conformation (G) these cancel but in the other (F) there is a net resultant. Since both forms exist in solution, there will be some dipole moment observed. The linear cyano groups in (E) however cause the net moment to be zero at all times.

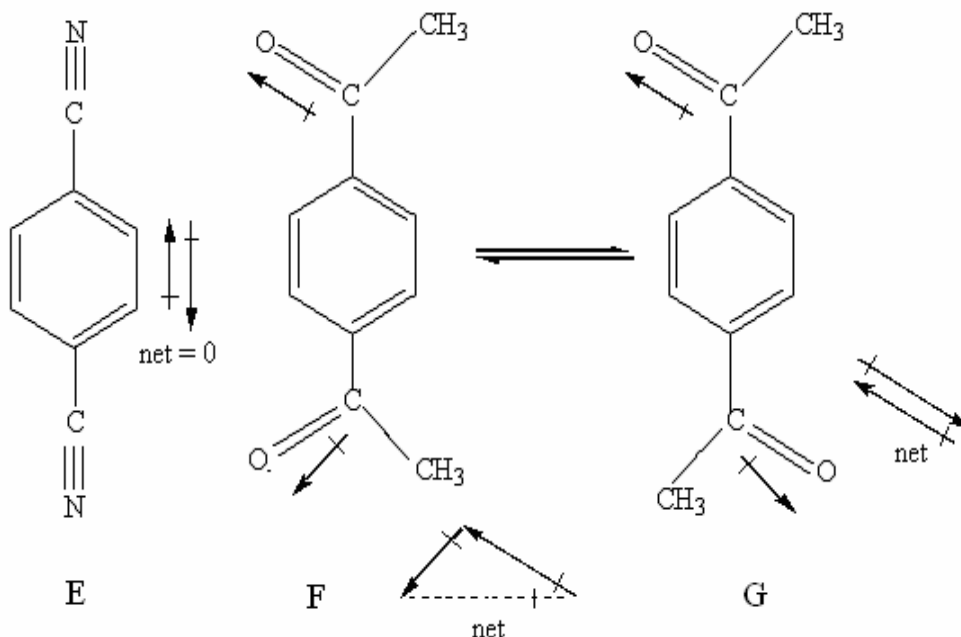

4. The dipole moment of CH_3F is 1.82 D and that of CH_3Cl is 1.94D. The apparent anomaly of CH_3F having a smaller μ than CH_3Cl is explained by the shorter C-F bond distance, which tends to decrease the value of μ even though F is more electronegative than Cl.

5. The dipole moment of CHCl_3 is less than that of CH_2Cl_2 . In CH_2Cl_2 all bond moments reinforce each other while in CHCl_3 the bond moment of one of the Cl's opposes the net moment of the other two. This effect is more apparent when the tetrahedral nature of the molecule is considered. (Figure 22.)

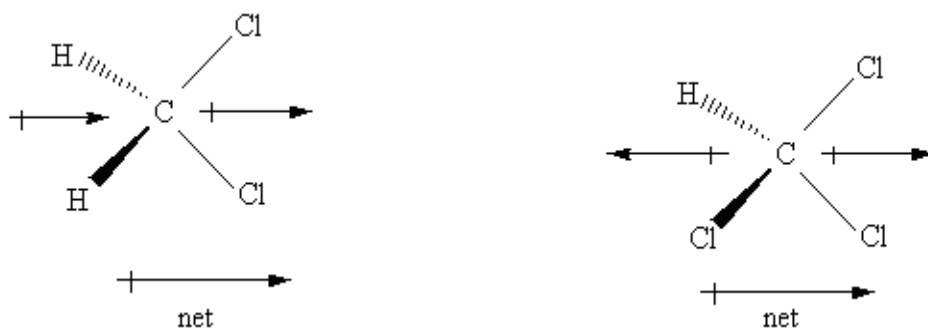

Figure 22. The dipole moments of CHCl_3 and CH_2Cl_2 .

REFERENCES

1. Exner, O. Dipole Moments in organic Chemistry, Georg Thieme Publishers, Stuttgart, Germany, (1975).
2. Liberles, A. Introduction to Theoretical Organic Chemistry, The Macmillan Company, USA, (1968).
3. Nasipuri, D. Stereochemistry of Organic Compounds: *Principles and Applications*, Wiley Eastern Limited, New Delhi, (1992).
4. Finar, I L. Organic Chemistry (vol. 1&II), ELBS with Longman, England, (1975).
5. Ferguson, L N. The Modern Structural Theory of Organic Chemistry, Prentice-Hall of India (Private) Ltd., New Delhi, (1966).
6. Branch, G E K and Calvin, M. The Theory of Organic Chemistry, P.135, The Macmillan Company, USA, (1965).