

## *Chapter 5*

### **LAND USE AND LAND COVER CHANGE DETECTION**

Identification and quantification of Land use and Land cover (LU and LC) changes in the study area are discussed in this chapter. Remote Sensing and GIS techniques are used to accomplish the objective of the study. For this, some methodologies based on the comparison between the satellite images are acquired on different dates, using the classification comparison and by using change detection matrix method. The detection results about the change in forms of the proportion of LU and LC classes and trajectories are also discussed with spatial emphasis on coastal shrimp culture development in the five coastal blocks of Purba Medinipur district of West Bengal. An attempt was also made to model the changes using Markov Chain and predict the LU and LC distribution by 2030.

#### **5.1 Introduction**

In the coastal ecosystem, the natural productivity is dependent on the LU and LC pattern of that region. Various human activities like agriculture and aquacultural activities have a great impact on the coastal ecosystem. Globally in coastal areas, shrimp culture has already expanded to a huge extent and hence a noticeable LU and LC change has been observed. The changes have adverse effects on the hydrology, catchment area, drainage system and biodiversity maintenance (Alonso-Perez et al., 2003). In global perspective, it has been seen that aquaculture activities including shrimp farming are mostly done in mangrove areas or rice field areas of the coastal region. In last few decades, Indian shrimp farming has experienced rapid growth (Section 2.1.1). Different researchers stated about the fast growth of coastal shrimp culture in India and pointed that it is the major driving force for landscape transformation like loss of agricultural land, mangrove deforestation etc. (Hossain et al., 2003, Rajitha et al., 2010). These changes have pointed towards the negative effects of shrimp farming which includes erosion, flood risks, soil and water quality degradation, loss of biodiversity etc. (Islam, 2000). The coastal environment receives cumulative impacts from nature. These changes directly or indirectly affect them adversely. These transformations contribute towards the global changes too.

Mankind's come on earth and in course of time and age they become the lord of the planet. From age to age and advancement of civilization and their needs multiplied and people all over the earth started modelling, remodelling and changing gradually. LU and LC changes for aquaculture or other co-lateral activity like this causing instability of land and environmental hazards not beneficial to human life and activity (Riebsame et al., 1994). So, it is required to understand, quantifying and monitoring the changes in process of landscape conversion to make sure about sustainable management of natural resources. The importance of monitoring, mapping and quantifying the changes in the physical properties of LU and LC have been widely accepted in the scientific community as the most important factor in global change study (IGBP, 1990; Henderson-Sellers and Pitman, 1992).

Several authors have acknowledged the need for up-to-date LU and LC information and acquiring accurate spatial information on LU and LC changes. The sustainable uses of earth's resources are very important to create a balance between economy, society and physical environment (Maingi and Marsh, 2001). LU and LC observation with the proper description is allowed in the field based study and that is in a detailed and spatially disaggregated way. Interaction between human activates with the environment and its impact on LU and LC is clearly visible through such studies. To know the LU and LC patterns with respect to time and space just doing the field study are not enough (Liverman et al., 1998). Hence the future change patterns cannot be predicted just based on field study.

For the quantitative measurement of the LU and LC changes at the landscape scale, remote sensing is considered to be a most useful data source (Hudak and Wessman, 1998). Present form of LU and LC pattern is mostly the result of human activities. These activities are different in different places and hence their magnitude and position are heterogeneous. In this situation remote sensing can be used for multi-temporal monitoring, disclosing the LU and LC changes and to provide necessary information related to LU and LC dynamics (Singh, 1989). For obtaining a series of synoptic data for geographically large areas uniformly in time and space remote sensing is the only way to do it without doing a detailed exhaustive field survey (Laba, et al., 1997). A variety of techniques have been used in remote sensing and other domains to identify spatial-

temporal variability in multivariate data. The traditional change detection techniques by visual comparison of air photos have slow, tiring and subject to the errors of omission (Sheppard, 1964). Most of methods are as simple as manual On-Screen Digitization of change (Boone et al., 2007). Other algorithms do more complex calculations (Eastman, 1999). A large number of documented change detection methods and algorithms are available based on the utilizing of remote sensing data.

To detect the changes in LU and LC, analysis involves with two registered multispectral remote sensing images acquired at two different times in the same geographic area. Such an analysis is aimed at identifying and quantifying LU and LC changes that have occurred in the particular study area between the two considered time periods.

Considerable amounts of data of the earth's surface can be collected by the remote sensing process. The utility of the remote sensing data in change detection is dependent not only on the spatial resolution and radiometric resolution of data but also on subsequent processing and the quality of the processed data (Townshend et al., 1992). Many error sources are linked to the products for LU and LC changes that are derived from remote sensing data. Data acquisition, processing, analysis and conversion are included in these sources and hence preprocessing of images are required before change detection.

Most of the current detection techniques for LU and LC change are critically dependent on the accuracy of the geometric registration of two images since the change analysis is normally done in pixel by pixel (Dia and Khorram, 1997). If a correct registration between images is not achieved, mock differences are only detected because the properties of the land surface at the wrong locations were an evolution rather than real changes at the same location between the one and the other (Townshend et al., 1992). In 1998, Dia carried out of the effects of incorrect image registration on the accuracy of change detection. The experimental result with Landsat Thematic Mapper (TM) showed that a registration accuracy of less than a fifth of a pixel is required to achieve an error in the detection of changes of less than 10%.

The assumption to use remote sensing data to detect LU and LC changes is because of the consistent relation between brightness values which are remotely sensed post

calibration and the actual surface conditions. The data are usually collected on different dates with different reactions from the sensor system, phenological variations, sun angle, atmospheric and soil moisture conditions (Lambin and Ehrlich, 1997). Paolini et al. (2006) performed a study using temporal, multi-sensor change detection of Landsat data. The study was focused on radiometric correction effects in the satellite. They evaluated the effects of absolute radiometric correction and relative radiometric correction method to determine the LU and LC changes, using Landsat TM and ETM<sup>+</sup> (Enhanced Thematic Mapper Plus) images. As a result, conclusion was made that absolute radiometric correction is required in multi-temporal multi-sensor Land use and Land cover change analysis.

With the help of this technique, the changes in the coastal system are easily detectable. This information is used for many important purposes under regular environmental stress induced by the activities in or around them.

Over the past decades, the use of satellite data has replaced the traditional field research methods in the preparation of LU and LC maps as a result of developments in remote sensing and geographical information systems (GIS). Google Earth images provide the high resolution satellite images, where the individual buildings are clearly visible and hence it will be carried out LU and LC change detection even at ward/mouza/village level, which will help the policy makers and planners to carry out proper planning and management activities. The advantage of Google Earth is that it delivers the latest satellite images with a spatial resolution of less than 1 meter. In the last few years, most famous image processing and GIS software such as ERDAS IMAGINE, ArcGIS, etc. have offered tools to visualize and import Google Earth images. Providing images taken at different time period is another advantage of Google Earth. This is very useful in case of LU and LC change detection studies but only very few studies have been conducted utilizing its advantageous and excellent data source for the preparation of the land use mapping (Ohri and Poonam, 2012; Jacobson et al., 2015). In Google Earth, it may not be possible to get original multispectral tape data and hence using supervised and unsupervised techniques classification of images cannot be performed. This is considered as the only limitation of Google Earth. But because the Google Earth's high spatial resolution visibility of buildings, roads, bridges, water bodies etc. are very clear

in the collected images and hence on-screen digitization can be done easily to prepare the LU and LC map.

By analyzing change trajectories and through temporal series of remote sensing data, dynamics of change processes can be investigated i.e. sequences of successive changes in LU and LC types are observed and analyzed (Turner et al., 1989; Singh, 1989). The goal of temporal series analysis is to project the temporal evolution of a landscape as well as to interpolate LU and LC distributions between the dates of observation (Lambin, 1997). By modelling the change process as stationary Markov process at a condition that the process is homogeneous in time, the short-term projections and interpolation of temporal data can easily be performed (Bell and Hinojosa, 1977).

Markov Chain models have been used in many research studies to generate probabilities of transition from one Land use and Land cover type to another across landscapes (Hall et al., 1991). Markov Chain model was applied by Weng (2002) to predict Land use and Land cover change dynamics which was a valuable process in predicting and analyzing LU and LC change process. With a series of MSS imagery, Markov Chain is also used for developing the rates of transition between forest ecological states (Hall et al., 1991). Zhang et al., (2011) applied the Markov Chain process to analyze the changes in wetland trends in the arid area. However, Eastman (1999) also pointed the weakness of Markov analysis for modelling change in LU and LC classes. He stated that the Markov analysis does not hold any sense of geography, so no spatial component will be produced in the modelling outcome. On the other hand, the results from the analysis hold true on a per category basis. According to Petit et al. (2001), the results obtained through Markov Chain analysis for future conditions point gradual increase in bare soils as well as cultivated land and drastic decrease in forest areas and vegetation covers. In 2010 Rajitha et al. applied the Markov chain process to predict the LU and LC change due to respects the coastal aquaculture. The LU and LC information, derived from Markov chain models, is useful for planners as well as policy makers to identify the most critical regions. According to Lambin and Ehrlich, 1997, it is very interesting to study the change in 'Hot spots' (where high rate of change is observed) areas of LU and LC change. To model the change process for the same is much fascinating. These 'hot spots' can be considered as a base to build the LU and LC change model, no matter if the

changes are much lower or different in the other region. Hence for both backward and forward projections this can be used to test the methods. The study area selected for present investigation is marked as one of the 'hot spot' in view of the coastal shrimp farming development in India (Section 3.4.1). Based on these aspects the objective of the present chapter is selected.

It elaborates about the identification as well as quantification of LU and LC changes occurred in five coastal blocks of Purba Medinipur district, West Bengal from 2008 to 2016 (data collected and compared for year 2008, 2012 and 2016), testing of a Markov based model for future prediction of LU and LC changes (for year 2030) and using multi-temporal satellite data with a spatial focus on coastal shrimp culture.

## **5.2 Materials and methods**

This section briefly discusses the details of satellite data used, LU and LC change detection approaches applied and details of Markov chains used for the prediction of LU and LC change within the study area. Brief methodology in the form of a flowchart of the study is presented in Figure 5.1.

### **5.2.1 Satellite data**

Satellite images acquired from Google Earth of 2008, 2012 and 2016 were used for the LU and LC change detection. To get the accurate information regarding the LU and LC changes classification of images are done in all the images. In order to ensure the accuracy of LU and LC change detection image pre-processing was carried out in all images which are briefly discussed in Section 4.1.

### **5.2.2 Comparison of Land use and Land cover classification and change detection matrix**

Land use and Land cover classification is done by using the process images collected with the help of Google Earth in the year 2008, 2012 and 2016. This classification is done through on-screen digitization process. In this present study, importance has been given to aquaculture development while doing the LU and LC classification, hence detailed classification of waterbody class has been done. Waterbody class is sub-divided into five (5) categories for level-III classification. Depending on image characteristics study area has been sub-divided in total twelve (12) different LU and LC classes. Image

characteristics are shown in Appendix–B. This classification is made by following the classification of National Remote Sensing Agency (NRSA, 1995). The classification scheme is shown in Table 4.2.

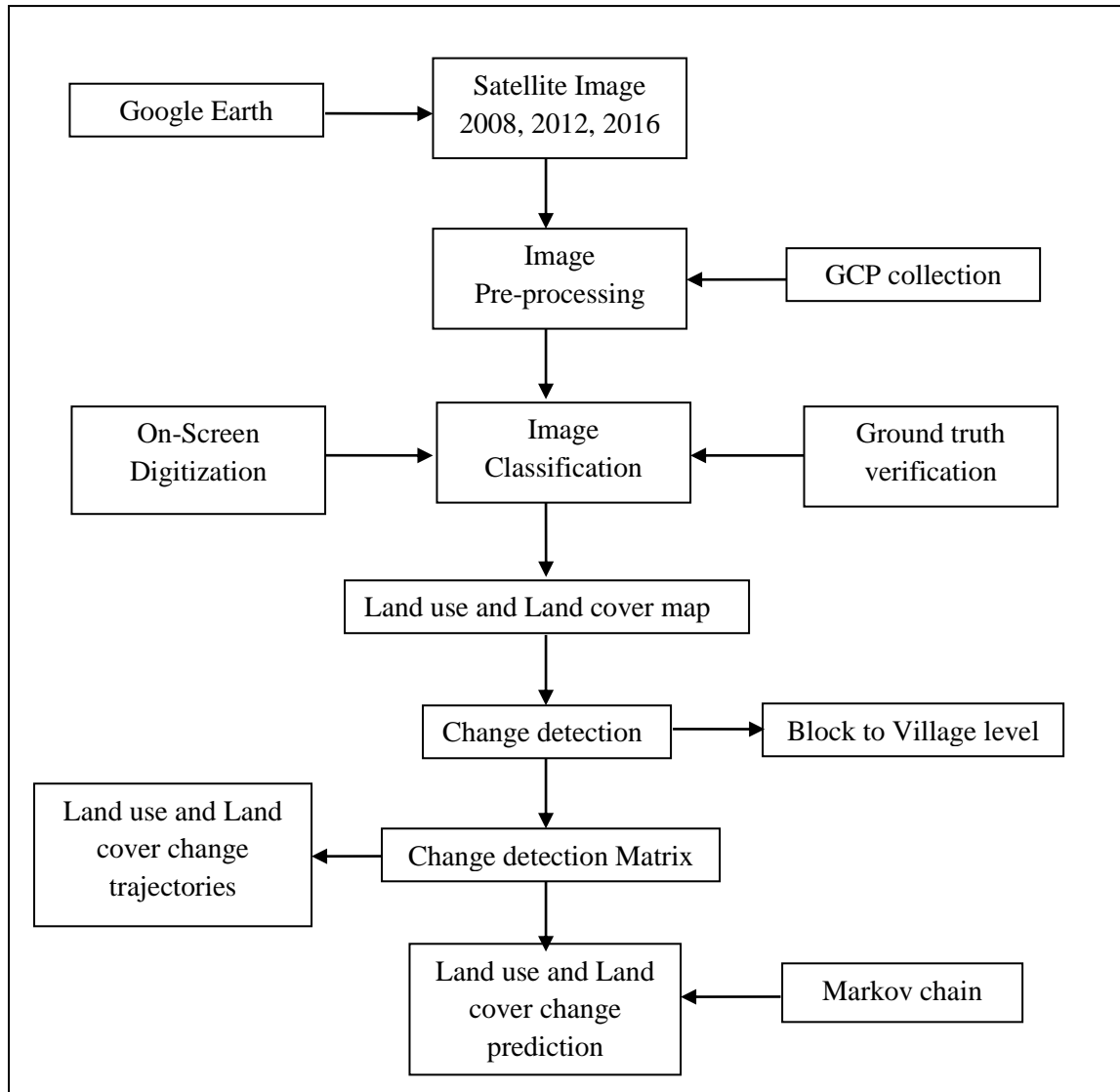

Figure 5.1 Flow chart for Land use and Land cover change detection and prediction

The general classified version of the real landscape is LU and LC classification. To verify the accuracy of LU and LC class ground truth verification is an unavoidable condition (Owojori and Xie, 2005). It should be done sincerely with utmost care. Total sixty-two samples have been checked by GPS to do the ground truth (GT) verification. For the year 2016 GT verification, physical verification has been done. For the year 2008, 2012 the GT verification is done with the help of the information collected from the local people of the study area. Using change detection matrix and by utilizing the data of LU

and LC classification for different years, changes in the land and nature of a particular spot with respect to time and also the rate of change is obtained. From change detection matrix also gives the details of year wise conversion from one class from the other. It is a two-way cross-matrix. In this present study with the help of change detection matrix “from-to” change of land use class is shown. “No-change” portion is also shown with the help of the same.

ArcGIS 10 and QGIS desktop 2.18.16 software have been used for LU and LC classification and change detection matrix accordingly. The detailed performance of change detection matrix is shown in the Figure. 5.2.

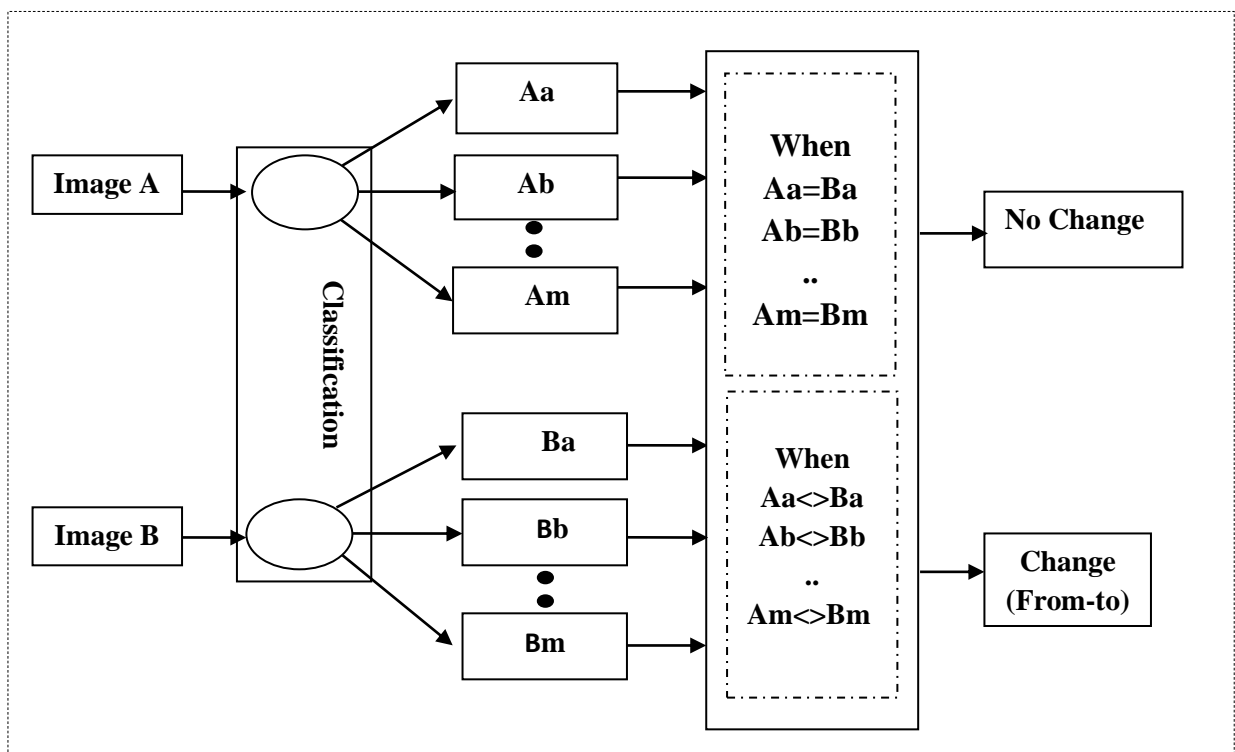

Figure 5.2 Methodology for change detection matrix

### 5.2.3 Land use and Land cover change prediction using Markov Chain

On the basis of the result obtained from change detection matrix, the Land use and Land cover change prediction has been done. By focusing on the differences of classes from the year 2008 to 2016, prediction of the LU and LC change of the year 2030 has been made. The Markov Chain model used for LU and LC change prediction is discussed in details in Section 4.1.10.



### **5.2.3.1 Markov Chain model validation:**

The role of prediction is to generate Land use and Land cover pattern that presents a close correspondent to the real world at a define point in time. However as the famous quote by a famous statistician George E. P. Box says “all models are wrong, but some are useful”, it is important to check the use fullness the prediction model in the concerned topic. LU and LC change processor are quite complex, there is no one to one mapping between LU and LC classes at two different time period. There are processes based model are not practical to implement to predict feature LU and LC (Epstein et al., 2002). Hence statistical model like Markov chain model has a role to play. The Same Markov chain model using past land cover data set to predict a known Land use and Land cover pattern has been used to validate the future Land use and land cover pattern. Specifically a prediction map for 2016 has been predicted using 2008 to 2012 then the confusion matrix has been calculated using the predicted and actual map.

## **5.3 Results**

The results of Land use and Land cover change detection obtained from classification comparison and change detection matrix are elaborately discussed in this section. This section also describes results of LU and LC change prediction using Markov Chain Modeling.

### **5.3.1 Land use and Land cover classification**

Satellite images of the year 2008, 2012 and 2016 collected through Google Earth are classified by the process of on-screen digitization. In the study area total twelve (12) LU and LC classifications has been made. There are – i) Agricultural land, ii) Settlement, which includes rural settlement, urban settlement, built up area, iii) Vegetation cover including coastal forest, mangrove and social plantation, iv) Sandy area consisting beach and sand dunes, v) Scrub land, vi) Brackish water tanks/ponds, vii) Fresh water tanks/ponds, viii) Nayanjuli (Roadside ditch) of linear water bodies along with the road, ix) River/Stream/Canal, x) Sea, xi) Waterlogged area, xii) Transportation including major road and rail line. The detailed statistical table of the classification of 2008, 2012 and 2016 is shown in Table 5.1.

Table 5.1 Land use and Land cover statistics for 2008, 2012 and 2016

Sl no	LU and LC category	Area in ha			Area change in ha		
		2008	2012	2016	2008 to 2012	2012 to 2016	2008 to 2016
1	Agricultural land	47990.56	47460.20	46045.25	-530.36	-1414.95	-1945.31
2	Bw tanks/ponds	4234.13	4719.86	5895.40	485.72	1175.54	1661.27
3	Fw tanks/ponds	3675.18	3707.55	3794.21	32.37	86.66	119.04
4	Settlement	18924.31	19006.74	19202.34	82.43	195.60	278.03
5	River/ stream/ canal	2330.29	2304.36	2303.90	-25.93	-0.46	-26.39
6	Transportation	963.73	963.73	963.73	0.00	0.00	0.00
7	Sandy area	379.39	359.45	330.10	-19.95	-29.35	-49.29
8	Scrub land	344.56	336.22	350.28	-8.34	14.07	5.72
9	Sea	1383.94	1383.94	1383.94	0.00	0.00	0.00
10	Nayanjuli	294.98	291.88	290.67	-3.10	-1.21	-4.31
11	Vegetation cover	1278.97	1266.11	1240.19	-12.85	-25.92	-38.77
12	Waterlogged area	8.54	8.54	8.55	0.00	0.01	0.01

From the above statistical analysis which has collected from LU and LC classification it is clearly visible that some of the LU and LC classes have experienced positive (increasing) changes whereas some other has gone through negative (decreasing) changes. The negative sign ( - ) is representing negative or decreasing changes. Among all noticeable positive changes, the brackish water tanks/ponds have experienced highest change. In 2008-2012, it has increased by 485.72 ha, and in between 2012-2016 it has increased by 1175.54 ha and hence from 2008-2016 a total increase of 1661.27 ha has been noticed. That means in the last four years (2012-2016) it has drastically increased and this rate is more than twice compared to first four years (2008-2012). In freshwater tanks/ponds, a total rise of 119.04 ha is noticed from 2008 to 2016, in which from the year 2008 to 2012, 32.37 ha and from the year 2012 to 2016, 86.66 ha area has been increased respectively. Similarly, in settlement area the total increment (from 2008-2016) has been noticed is of 278.03 ha and in scrubland is of 5.72 ha.

While mentioning about negative changes in the classes the first name comes is agricultural land. This class has experienced great loss and which results in a decrease of total 1945.31 ha from year 2008 to year 2016. During year 2008 to 2012, it has decreased by 530.36 ha, and in 2012- 2016 it is decreased by 1414.95 ha. Other classifications which have experienced negative changes are sandy area, vegetation cover, river/stream/canal and nayanjuli where the total decrease noticed (2008-2016) are

49.23 ha, 38.77 ha, 26.39 ha and 4.31 ha respectively. No such deviations are noticed in transportation, sea and waterlogged areas. The LU and LC maps of the whole study area of 2008, 2012 and 2016 are shown in the Figure 5.3. The block wise LU and LC maps are shown in Figure 5.4, Figure 5.5 and Figure 5.6 respectively.

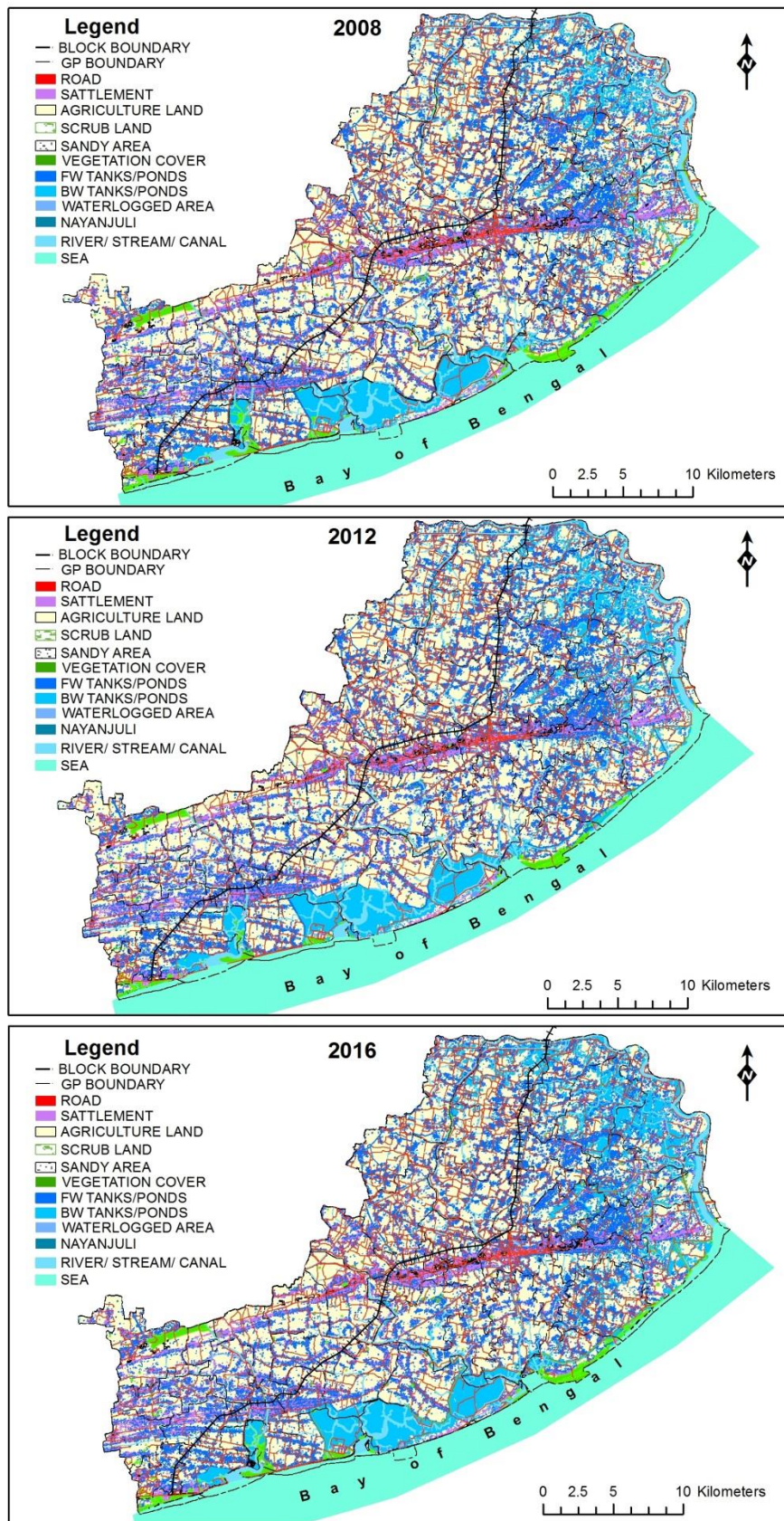

Figure 5.3 Land use and Land cover map of 2008, 2012 and 2016

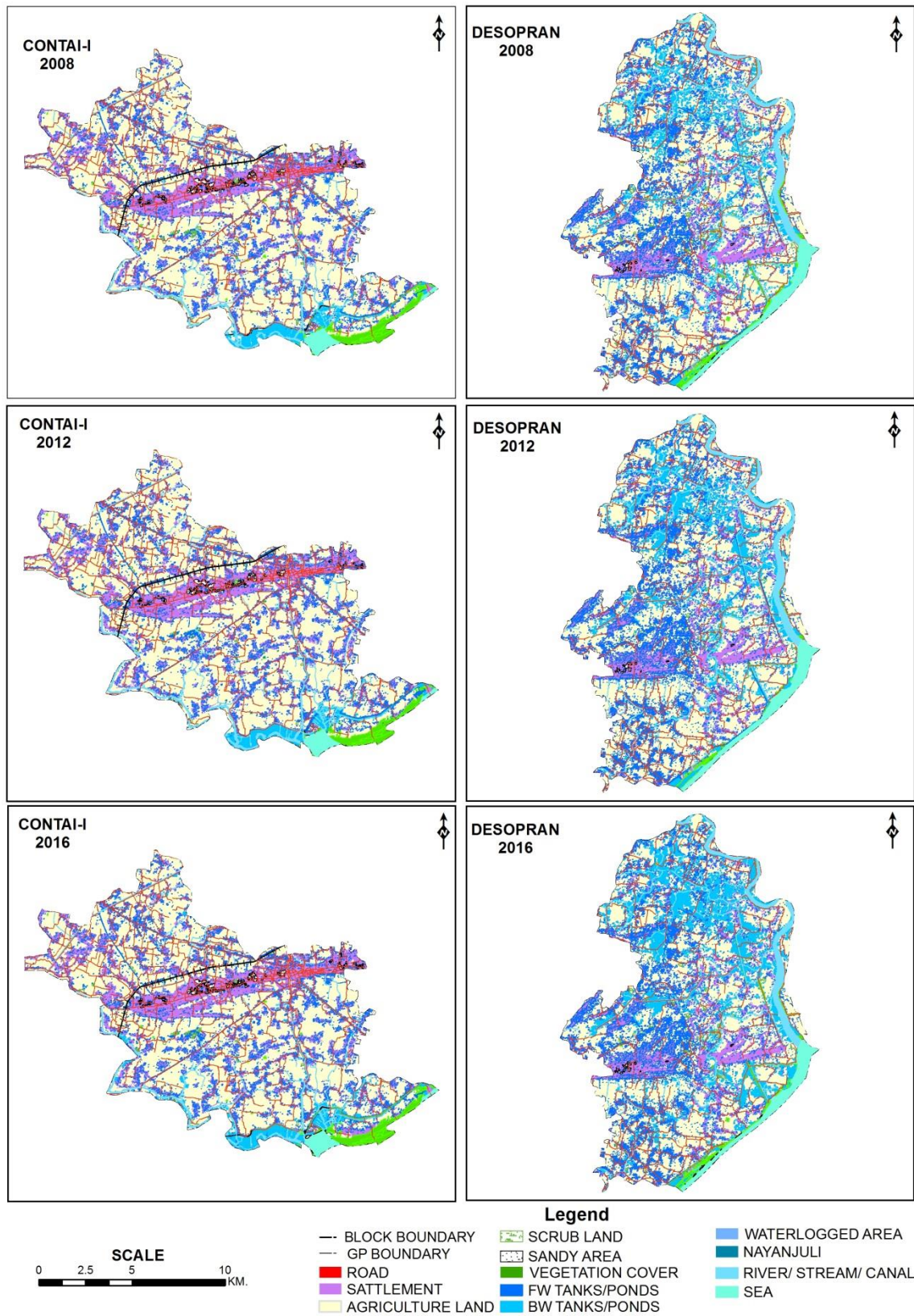

Figure 5.4 Land use and Land cover map of Contai-I & Desopran block for year 2008, 2012 and 2016

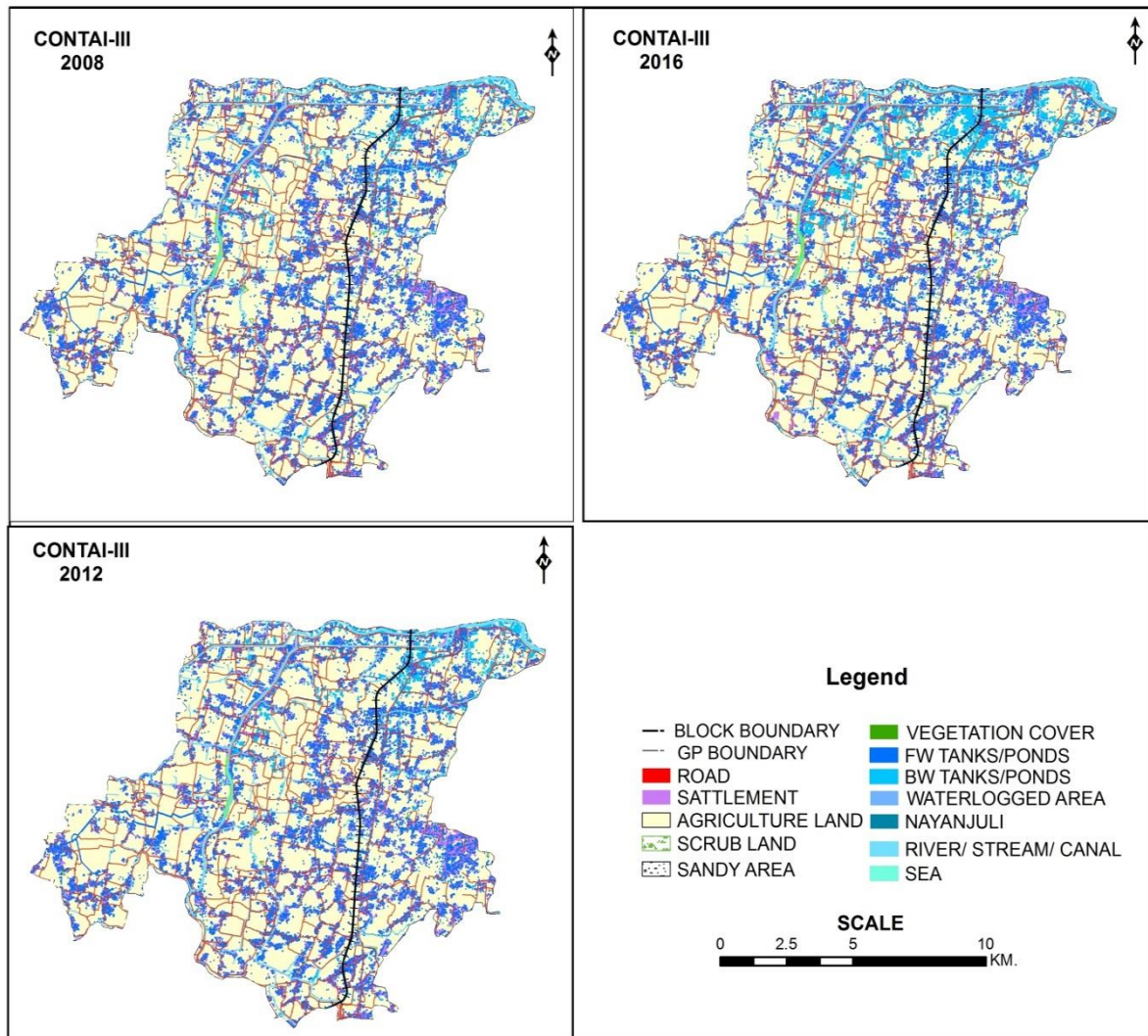

Figure 5.5 Land use and Land cover map of Contai-III block for year 2008, 2012 and 2016

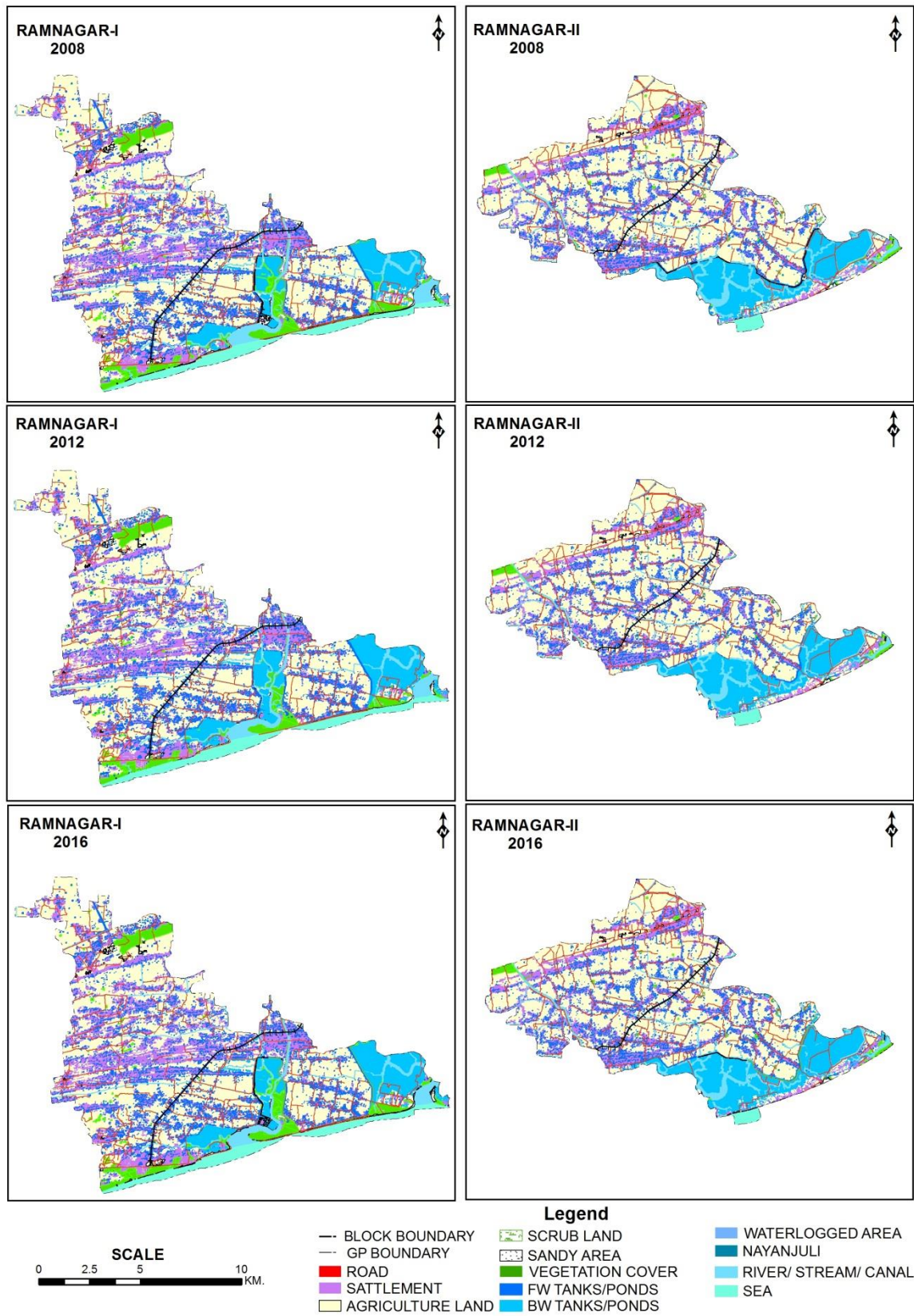

Figure 5.6 Land use and Land cover map of Ramnagar-I & Ramnagar-II block for year 2008, 2012 and 2016

### 5.3.2 Land use and Land cover change detection

By analyzing the results of different classes with the help of Land use and Land cover classification and change detection matrix, the classes which have undergone change are found out. For simplicity of analysis sixteen changed classes has selected carefully for this study which is shown in Appendix-B. Those changed LU and LC classes, where the area is less than 1 ha are intentionally ignored in this study. Detailed of LU and LC change (from-to) statistics are shown in the Table 5.2.

Table.5.2 Summary of the statistic of Land use and Land cover conversion for the period 2008-2016

Sl No	'From' class	'To' class	Area of conversion(ha)	Percentage of conversion (%)
1	Agricultural land	Bw tanks/ponds	1542.83	3.215
2	Agricultural land	Settlement	266.18	0.555
3	Agricultural land	Fw Tanks/ponds	131.28	0.274
4	Vegetation cover	Bw tanks/ponds	31.35	2.451
5	River/ stream/ canal	Bw tanks/ponds	26.29	1.128
6	Sandy area	Scrub land	25.14	6.626
7	Fw Tanks/ponds	Bw tanks/ponds	18.09	0.492
8	Scrub land	Bw tanks/ponds	17.75	5.152
9	Sandy area	Bw tanks/ponds	17.30	4.561
10	Vegetation cover	Settlement	6.92	0.541
11	Sandy area	Settlement	4.89	1.289
12	Nayanjuli	Bw tanks/ponds	3.95	1.340
13	Vegetation cover	Fw Tanks/ponds	2.07	0.162
14	Sandy area	Fw Tanks/ponds	1.77	0.466
15	Scrub land	Fw Tanks/ponds	1.61	0.467
16	Agricultural land	Vegetation cover	1.52	0.003

Shrimp farming has made a noticeable positive (increasing) change in the class of brackish water tanks/ponds. Mostly the agricultural lands are converted into brackish water tanks/ ponds. 1542.83 ha (3.21%) of agricultural land has been converted to brackish water tanks/ponds from the year 2008 to 2016. Apart from this 31.35 ha (2.45%) vegetation cover, 26.29 ha (1.12%), river/ stream/canal, 17.75 ha (5.15%) scrub land, 17.30 ha (4.56%) sandy area, 3.95 ha (1.34%) nayanjuli has been converted into brackish water tanks/ponds (the percentage values mentioned are the percentage of the area covered by



a particular class). 266.18 ha (0.55%) agricultural land, 6.92 ha (0.54%) vegetation cover, 4.89 ha (1.29%) sandy area has been converted into settlement class. In case of freshwater tanks/ponds 131.28 ha (0.27%) agricultural land, 2.07 ha (0.16 %) vegetation cover, 1.77 ha (0.46%) sandy area has been converted into fresh water tanks/ponds. Again 25.14 ha (6.62%) of the sandy area has been turned into scrub land. The agricultural land has been converted into three different classes which are brackish water tanks/ponds (1542.83 ha), settlement (266.18 ha), freshwater tanks/ponds (131.28 ha). The great impact of shrimp farming has been noticed on LU and LC changes from the year 2008 to 2016 on the basic statistical data. The detailed conversion table of LU and LC classes from the year 2008-2012 and 2012- 2016 has been shown in Table 5.3 and Table 5.4. These changes are shown by highlighting the change in the Figure 5.8 and Figure 5.9

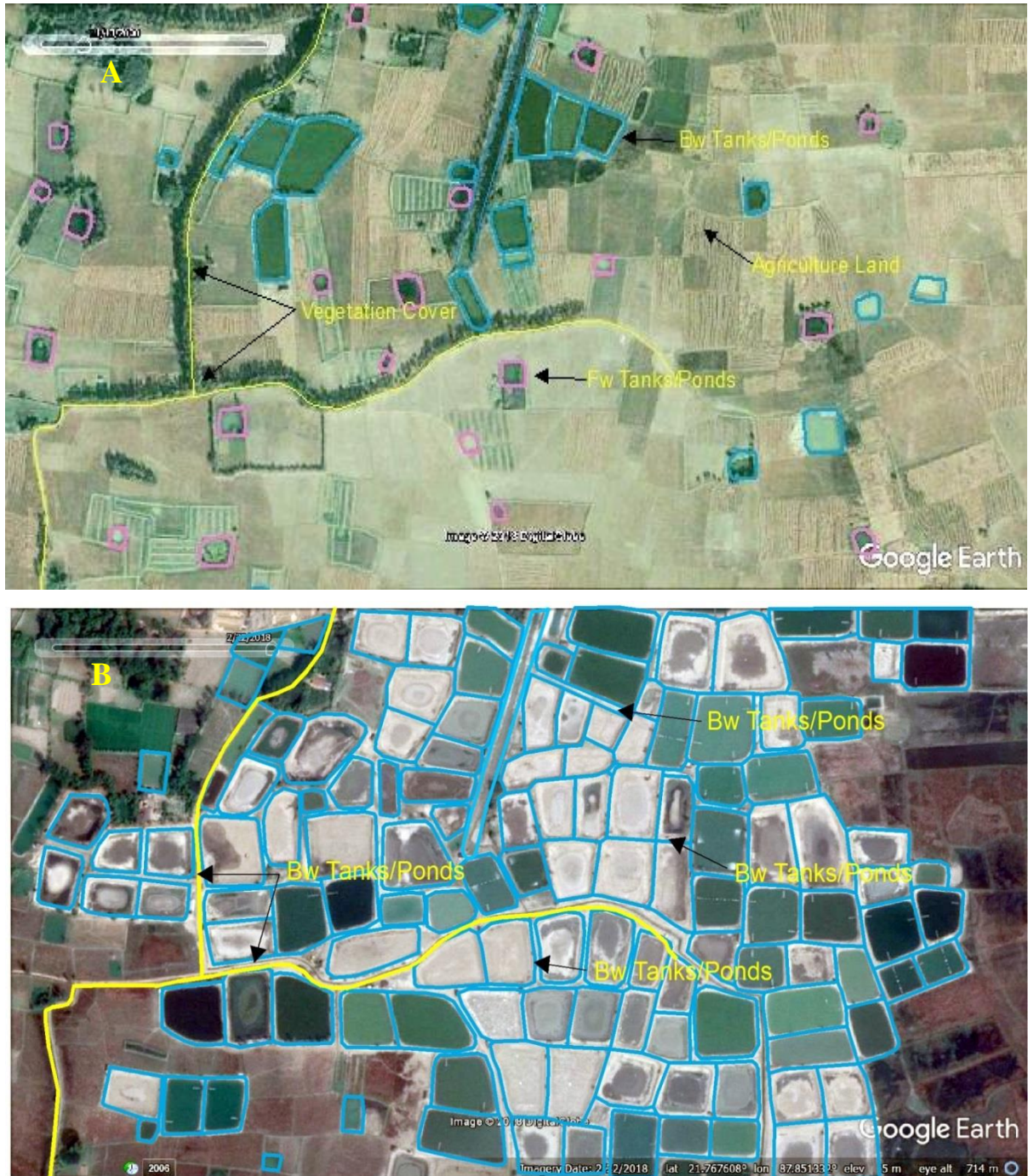

Figure 5.7 Google Earth view of Land use and Land cover change in Hajrakola mouza of Desopran block. Fig. A. (for year 2008) and Fig. B. (for year 2016) represent a particular portion of the study area and the arrow pointers indicate the LU and LC changes/unchanged portion of the same land from the year 2008 to 2016. It is clearly seen that wherever fresh water tanks/ponds or agricultural lands were present in 2008, most of these have been converted to brackish water tanks/ponds in the year 2016. Along with that, the adjacent trees of the brackish water tanks/ponds have been cut off.

Table 5.3 Change detection/ transition matrix between 2008 & 2012

LU and LC category		2012											Total area (ha)	
		Ag	Bwtp	Nj	W	Tp	Sa	Sm	Sl	S	Fwtp	Vc		Wl
2008	Ag	<b>47460.12</b>	416.09					76.92			32.03	5.40		47990.56
		<b>0.989</b>	0.01					0.002			0.001	0.0001		
	Bwtp		<b>4234.13</b>											4234.13
			<b>1.000</b>											
	Nj		3.07	<b>291.88</b>										294.98
			0.010	<b>0.990</b>										
	W		25.83		<b>2304.36</b>									2330.29
			0.011		<b>0.989</b>									
	Tp					<b>963.73</b>								963.73
						<b>1.000</b>								
	Sa		16.06				<b>359.45</b>	3.84						379.39
			0.042				<b>0.947</b>	0.010						
	Sm						<b>18924.31</b>							18924.31
							<b>1.000</b>							
Sl		8.24						<b>336.22</b>					344.56	
		0.024						<b>0.976</b>						
S									<b>1383.94</b>				1383.94	
									<b>1.000</b>					
Fwtp		0.82								<b>3674.35</b>			3675.18	
		0.0002								<b>0.9998</b>				
Vc		15.60					1.67			0.90	<b>1260.71</b>		1278.97	
		0.012					0.001			0.001	<b>0.986</b>			
Wl												<b>8.54</b>	8.54	
												<b>1.000</b>		
Total area (ha)		47460.12	4719.86	291.88	2304.36	963.73	359.45	19006.74	336.22	1383.94	3707.55	1266.11	8.54	81808.58

Table 5.4 Change detection/ transition matrix between 2012 & 2016

LU and LC category		2016												Total area (ha)
		Ag	Bwtp	Nj	W	Tp	Sa	Sm	Sl	S	Fwtp	Vc	Wl	
2012	Ag	<b>46044.90</b>	1126.74					188.73			99.74			47460.20
		<b>0.970</b>	0.024					0.004			0.002			
	Bwtp		<b>4719.85</b>											4719.86
			<b>1.000</b>											
	Nj		0.88	<b>290.67</b>										291.88
			0.003	<b>0.996</b>										
	W				<b>2304.36</b>									2304.36
					<b>1.000</b>									
	Tp					<b>963.73</b>								963.73
						<b>1.000</b>								
	Sa		1.25				<b>330.10</b>	1.05	25.14		1.72			359.45
			0.003				<b>0.918</b>	0.003	0.070		0.005			
	Sm							<b>19006.74</b>						19006.74
								<b>1.000</b>						
	Sl		9.51						<b>325.14</b>		1.51			336.22
		0.028						<b>0.967</b>		0.004				
S									<b>1383.94</b>				1383.94	
									<b>1.000</b>					
Fwtp		17.75								<b>3689.76</b>			3707.55	
		0.005								<b>0.995</b>				
Vc		18.97					5.78			1.17	<b>1239.91</b>		1266.11	
		0.015					0.005			0.001	<b>0.979</b>			
Wl												<b>8.54</b>	8.54	
												<b>1.000</b>		
Total area (ha)		46044.90	5895.40	290.67	2304.36	963.73	330.10	19202.34	350.28	1383.94	3794.21	1240.19	8.55	81808.58

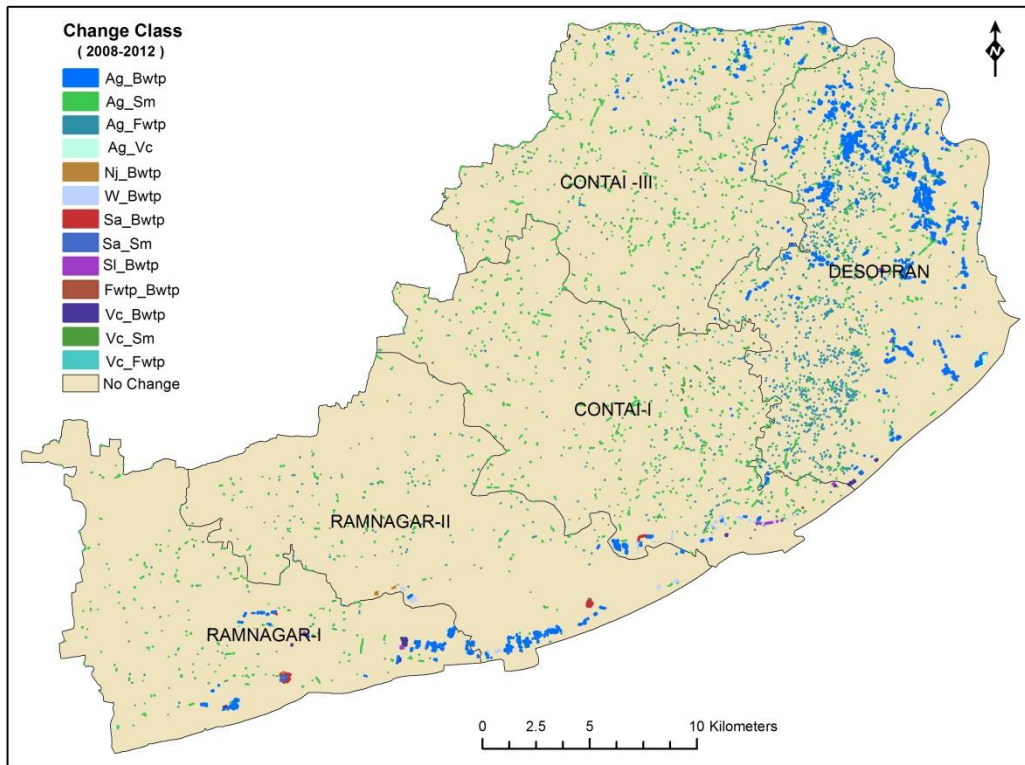

Figure 5.8 Land use and Land cover change map for the period of 2008 to 2012

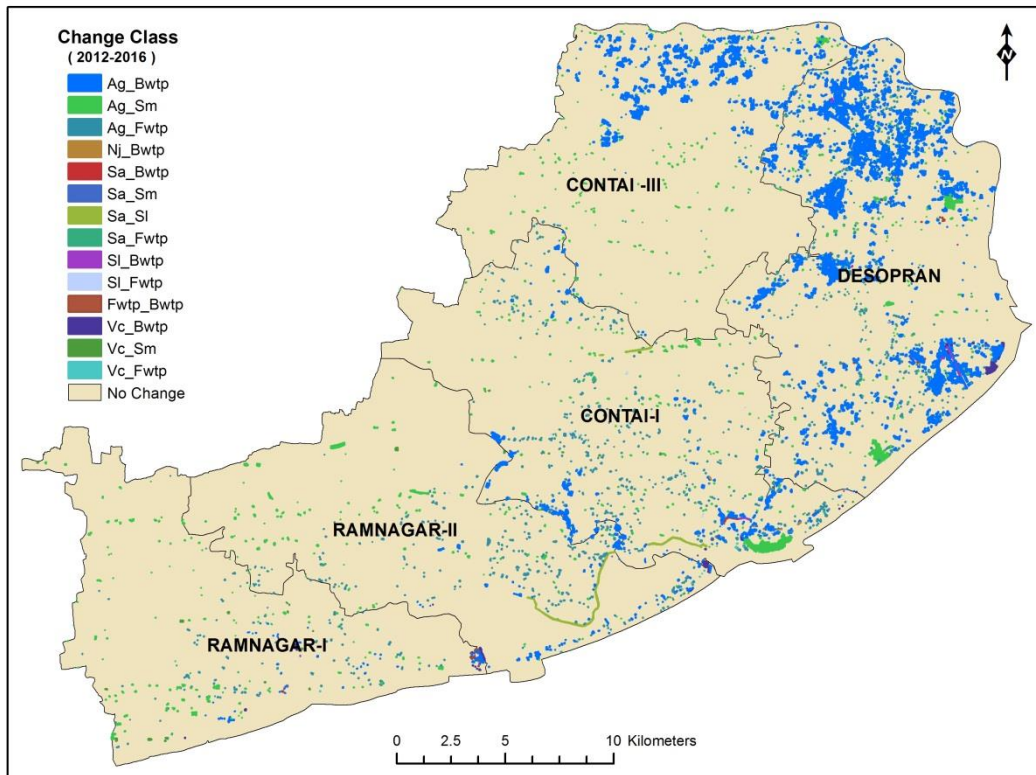

Figure 5.9 Land use and Land cover change map for the period of 2012 to 2016

### 5.3.3 Growth pattern of shrimp farming

By analyzing the block-wise statistical values obtained from change detection matrix (Table 5.5) of brackish water tanks ponds in the five different blocks of the study area, it is noticed that the Ramnagar-II block has the highest brackish water area, which is 2000.27 ha and a number 2385 in quantity. These values are obtained for the year 2016. In the year 2008 and 2012, the areas and quantities are accordingly 1887.24 ha, 1790 number and 1953.51 ha, 2019 number. From the year 2008 to 2016 the total area has been increased by 113.03 ha and the quantity has been increased by 595 numbers. In Ramnagar-I, the areas and quantities are accordingly 937.20 ha, 1050 numbers; 998.69 ha, 1348 number; 1007.27 ha, 1438 number for the year 2008, 2012 and 2016. Hence from 2008 to 2016 total 70 ha in area and 388 numbers in quantity has been increased in Ramnagar-I. Similarly in Contai-I the area and quantity of brackish water tanks/ponds has been increased and the total value increased in area by 163.37 ha and in quantity by 967 numbers from the year 2008 to the year 2016. In Desopran block the total brackish water area in 2008 was 922.02 ha and quantity 6417 number, which has increased to 1206 ha in area and 8325 in quantity in the year 2012. In 2016 these values are increased to 1965 ha and 12736 number. The total change noticed from 2008 to 2016 is 1042.98 ha in area and 6319 numbers in quantity for Desopran. The block Contai-III has also experienced a positive (increasing) change in the class of brackish water tanks/ponds and the area has increased by 271.81 ha and 1619 numbers in quantity from the year 2008 to 2016. By analyzing the changes happened to all five blocks of the study area, it has been noticed that the Desopran block has experienced highest change followed by Contai-III, which is second highest and Ramnagar-I block has experienced the lowest change in terms of area and quantity.

Table 5.5 Blockwise statistics of shrimp farm in the year of 2008, 2012 and 2016

Block Name	Number and area under each block for different Years					
	2008		2012		2016	
	No	Area (ha)	No	Area(ha)	No	Area (ha)
Ramnagar-I	1050	937.20	1348	998.69	1438	1007.27
Ramnagar-II	1790	1887.24	2019	1953.51	2385	2000.27
Contai-I	664	287.54	808	326.44	1631	450.91
Desopran	6417	922.02	8325	1206.01	12736	1965.00
Contai-III	1295	200.14	1491	235.20	2914	471.95

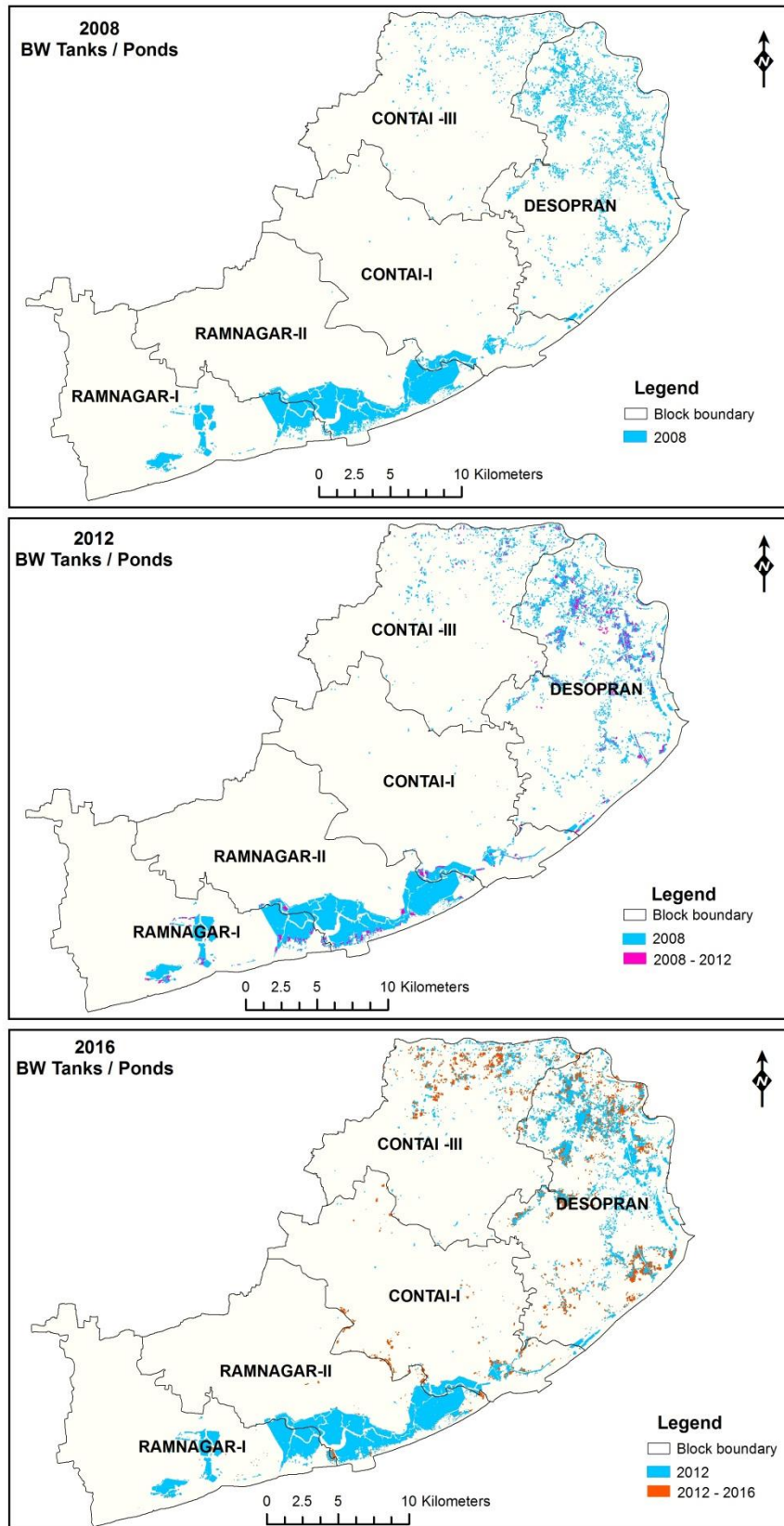

Figure 5.10 Map showing the increase in brackish water tanks/ponds in all five coastal blocks

### 5.3.4 Shrimp farming at Gram Panchayat level

By analyzing the data related to water bodies (year 2016) on the basis of Gram Panchayats (GP) it is seen that shrimp farming has its influence in 32 numbers of GPs out of total 42 GPs and in 1 Municipality. The Gram Panchayat called Kalindi has highest shrimp farming area i.e 1813.25 ha which is 36% of the total area of Kalindi. Apart from Kalindi more than 100 ha area of shrimp farming is observed in total 14 numbers of GPs. In those GPs more than 5% area is covered with shrimp farming. Those GPs are- Talgaccari-II, Amtolia, Auray, Dariapur, Kumirda, Padima-II, Satilapur, Kanaidighi, Nayaput, Majilapur, Dhobaberia, Sarada, Sabajput, Basantia. The Table 5.6 below is showing clearly the data of GP level shrimp farming hotspot.

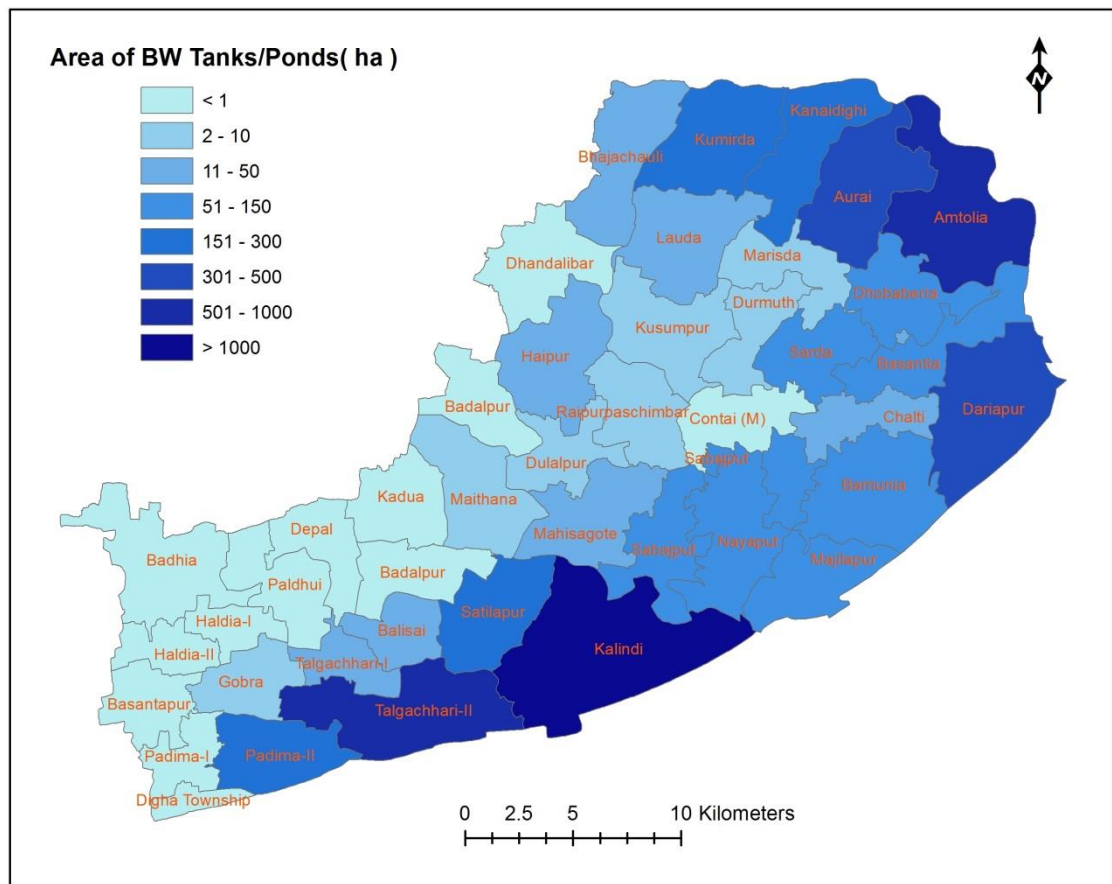

Figure 5.11 Spatial variation in shrimp culture area obtained for different Gram Panchayats



Table 5.6 Gram Panchayat wise statistic of shrimp farm for the year of 2016

Sl. No.	Gram Panchayat Name	Block	Bw Tanks/ponds		Hot spot Rank*
			Area(ha)	%	
1	Kalindi	Ramnagar-II	1813.25	36.4	1
2	Talgachhari-II	Ramnagar-I	785.72	25.3	2
3	Amtolia	Contai-II	605.08	18.1	4
4	Aurai	Contai-II	498.60	19.4	3
5	Dariapur	Contai-II	341.50	10.6	6
6	Kumirda	Contai-III	226.88	9.2	7
7	Padima-II	Ramnagar-I	201.70	11.6	5
8	Satilapur	Ramnagar-II	166.02	8.5	8
9	Kanaidighi	Contai-III	156.89	7.3	10
10	Nayaput	Contai-I	149.83	6.3	11
11	Majilapur	Contai-I	145.73	5.6	13
12	Dhobaberia	Contai-II	141.05	7.9	9
13	Bamunia	Contai-II	134.26	4.8	
14	Sarda	Contai-II	111.56	7.3	10
15	Sabajput	Contai-I	109.52	5.8	12
16	Basantia	Contai-II	101.28	5.5	14
17	Bhajachauli	Contai-III	46.97	2.1	
18	Chalti	Contai-II	31.67	2.4	
19	Mahisagote	Contai-I	31.20	1.5	
20	Lauda	Contai-III	29.34	1.3	
21	Balisai	Ramnagar-II	19.07	1.8	
22	Talgachhari-I	Ramnagar-I	12.87	1.4	
23	Haipur	Contai-I	10.37	0.4	
24	Gobra	Ramnagar-I	6.95	0.5	
25	Kusumpur	Contai-III	5.26	0.2	
26	Durmuth	Contai-III	3.65	0.3	
27	Marisda	Contai-III	2.81	0.2	
28	Raipur paschimbar	Contai-I	2.50	0.1	
29	Maithana	Ramnagar-II	1.94	0.1	
30	Dulalpur	Contai-I	1.66	0.1	
31	Dhandalibar	Contai-III	0.15	0.0	
32	Contai (M)	Contai-I	0.11	0.0	
33	Digha Township	Ramnagar-I	0.03	0.0	

\*Gram panchayats with 5% or more Brackish water (Bw) tanks/ponds area are ranked

### 5.3.5 Plot wise Land use and Land cover change detection

Effects of shrimp farming are clearly visible while observing the plot wise changes in the mouzas. When focusing on the previous data of plot wise land distribution and comparing it to the present condition, huge changes in plots are observed. For this research, a village called Purba Amtolia of Desopran block is taken into consideration to analyze the plot wise Land use and Land cover changes due to shrimp farming. Purba Amtolia (JL No- 447) block is the hotspot village for shrimp culture. The geographic location of the village 21° 49' 56" N to 21° 51' 12" N latitude; 87° 51' 50" E to 87° 52' 21" E longitude. It covers approximately 259.69 ha and consists of 1451 LR plots. From year 2008 to 2016 total 252 number of LR plots have been converted to brackish water tanks/ponds. In which 186 plots of agricultural land; 55 plots of freshwater tanks ponds; 10 plots which had vegetation cover and 2 plot of scrub land are all or partly being converted to brackish water tanks ponds (Table 5.7). In this particular mouza the growth of brackish water tanks/ponds is noticed by 39.83 ha (15 %) increment. Again 14.21 ha i.e 16.25% of agricultural land has decreased here. Scrubland and settlement area is increased by 3.14 ha (1.2%) and 1.88 ha (0.72%). 1.23 ha (0.47 %) of freshwater tanks/ponds and 1.38 ha (0.53%) of vegetation cover area is decreased in this mouza. That means the main reason behind these changes in the plots is shrimp farming. Not only in Purba Amtolia but also in the whole area the changes of plots due to shrimp farming are clearly visible.

In the Figure 5.12, the plot wise changes in Purba Amtolia due to shrimp farming is shown clearly.



Figure 5.12 Plot wise expansion of shrimp farms for three different years (2008, 2012, 2016)

Table 5.7 Plot wise conversion of brackish water tanks/ponds from other classes during 2008 to 2016 of Purba Amtolia Mouza (JL No.447)

Converted Brackish Water Tanks/Ponds from others class	2008 to 2012	2012 to 2016
	LR Plot No	LR Plot No
Agricultural Land to Bw Tanks/Ponds	34,35,36,37,96,117,172,177,178,179,181,182,183,184,186,192,200,201,202,204,207,208,214,215,216,227,421,422,424,605,609,610,1405,1441,675,691,692,693,695,696,697,698,699,700,707,709,752,753,812,813,829,845,870,871,872,873,987,1105,1106,1118,1136,1137,1138,1141,1229,1238,1356,1367,1369,1370	47,48,75,78,87,88,89,90,91,92,96,97,98,108,109,114,115,116,132,136,137,138,139,140,141,156,157,160,185,186,187,188,191,193,194,195,196,197,199,200,201,202,203,204,207,210,214,227,345,347,350,351,412,424,450,451,454,460,478,480,481,482,509,547,550,551,554,556,557,558,565,658,1403,1420,1430,1431,1432,1433,806,807,808,837,850,851,856,863,865,866,867,868,869,900,936,986,1001,1006,1007,1030,1033,1059,1060,1066,1068,1071,1099,1141,1248,1279,1331,1332,1356,1358,1359,1360,1361,1380,1381,1461
Fw Tanks/Ponds to Bw Tanks/Ponds	172,185,348,424,694,708,1137,1138	30,38,39,52,53,54,57,208,411,642,808,809,837,850,851,870,874,875,1021,1026,1027,1028,1029,1030,1049,1112,1117,1120,1123,1348,1384,1140,1189,1200,1331,1332,1333,1454,1455,1456,
Vegetation Cover to Bw Tanks/Ponds	173,808,809,861,862,1356,	904,1273,1274,1369
Scrubland to Bw Tanks/Ponds	173	172

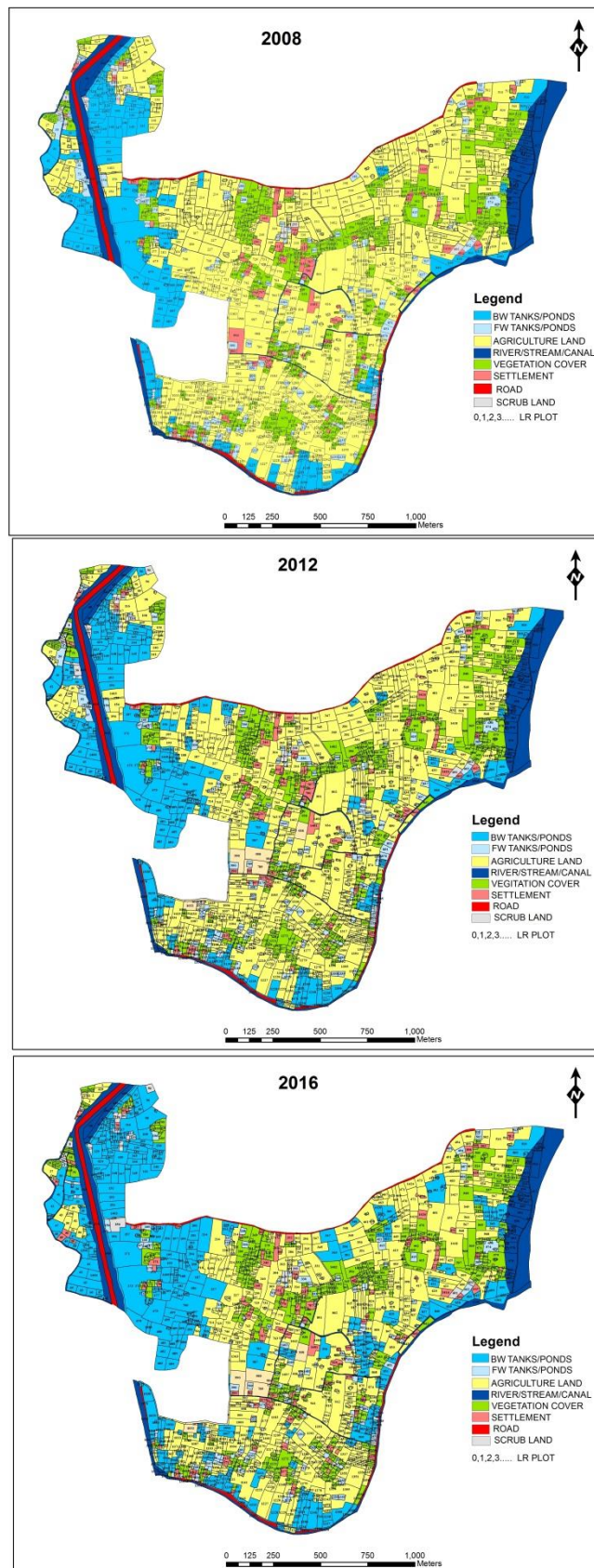

Figure 5.13 LR plot wise Land use and Land cover change map for the period 2008 to 2016 of Purba Amtolia Mouza (JL No.447)

### 5.3.6 Land use and Land cover change prediction using Markov Chain

Markov Chain Model is the process following which of LU and LC change prediction is done. Conditional probability of change = 1 - no-change conditional probabilities, (i.e. the numbers on the diagonal of the transition matrix) was determined for different LU and LC categories for the successive observation pair of years (i.e. 2008-2012; 2012-2016). For the calibration of Markov Chain Model, the pairs which have a minimum difference in conditional probabilities of change for different LU and LC categories are selected. For most of the LU and LC categories, it is seen that no two observation pairs of years have shown similar changes in conditional probabilities. Hence the average changes from the year 2008-2016 are taken into account for future prediction of LU and LC changes for the year 2030.

The overall accuracy of the Markov chain model based on the previous LU and LC to predict the known LU and LC is 87.99% (Table 5.8). There for the accuracy of the future LU and LC is principally acceptable. A Comparison of class wise predicted an actual LU and LC area is portrayed in Figure 5.14.

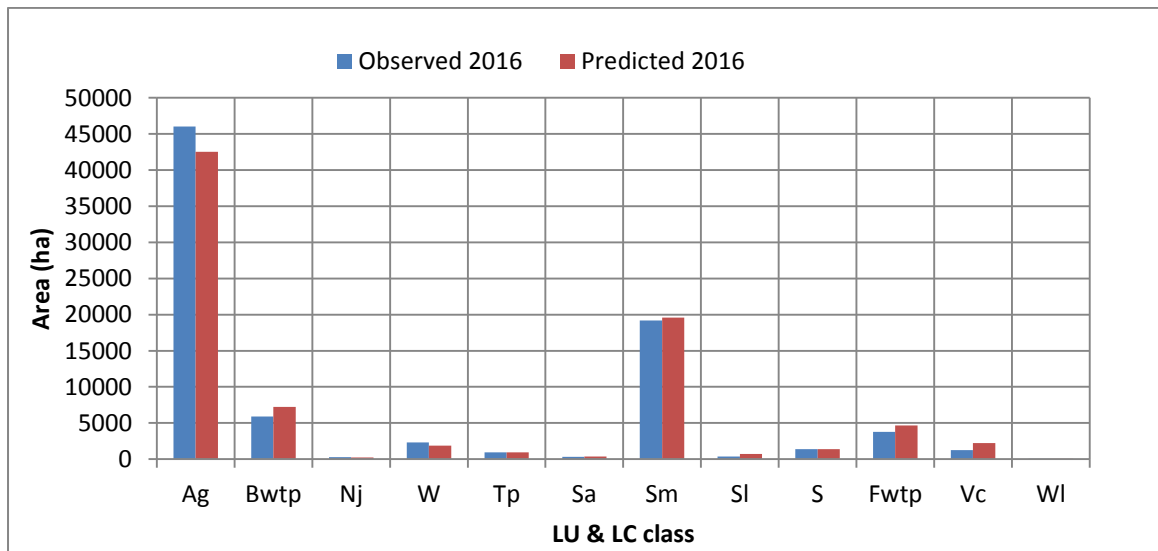

Figure 5.14 Comparison between Land use and Land cover projected of 2016 from the transition matrix between 2008 and 2012 and observed Land use and Land cover value of 2016.

Table 5.8: Transition matrix between predicted Land use and Land cover of 2016 and observed Land use and Land cover of 2016

LU and LC category		Predicted 2016												
		Ag	Bwtp	Nj	W	Tp	Sa	Sm	Sl	S	Fwtp	Vc	Wl	Total area (ha)
Observed 2016	Ag	<b>40096.93</b>	3212.33				40.81	550.11	294.00		946.78	895.84	8.44	46045.25
	Bwtp	2251.22	<b>3247.54</b>	0.19	0.01		2.45	3.87	97.75		128.29	164.09		5895.40
	Nj		31.75	<b>236.00</b>							22.92			290.67
	W		429.00		<b>1874.90</b>									2303.90
	Tp					<b>963.73</b>								963.73
	Sa		34.78				<b>258.00</b>	7.52	28.93		0.87			330.10
	Sm	80.96					27.40	<b>19036.26</b>			6.18	51.54		19202.34
	Sl		15.66				13.36		<b>297.88</b>		23.38			350.28
	S									<b>1383.94</b>				1383.94
	Fwtp	81.03	180.76					2.75			<b>3494.23</b>	18.92	16.52	3794.21
	Vc	13.93	75.79				4.15				54.82	<b>1091.49</b>		1240.19
	Wl		7.08										<b>1.46</b>	8.55
	Total area (ha)	42524.07	7234.69	236.19	1874.90	963.73	346.19	19600.52	718.56	1383.94	4677.48	2221.89	26.42	<b>81808.58</b>

Overall Accuracy: 87.99%

The figure which is obtained from Markov Chain Model explains the predicted LU and LC changes for year 2030 considering that there is no change in technology and policies in between year 2016 to 2030. This LU and LC distribution prediction (Figure 5.15) shows that the shrimp culture area will increase and become to 8528.62 ha in 2030 (i.e. it will increased by 2633.22 ha) from 5895.40 ha of 2016 and the agricultural land will decrease from 46045.25 ha (in 2016) to 43084.29 ha in 2030. It is expected that scrubland, waterlogged area, nayanjuli will be in the stabilized condition in 2030, because there will be a minor change observation for that area. According to the prediction, the settlement area would increase by 272.43 ha and fresh water tanks/ponds would increase by 264.75 ha. Sandy area and vegetation cover area would be decreased by 66.60 ha and 59.95 ha. The highest area in shrimp farming would increase in Desopran (1573.03 ha) block followed by Contai-III (458.15 ha), Contai-I (267.34 ha), Ramnagar-II (189.93 ha), Ramnagar-I (126.59 ha) accordingly. Similar to the previous years, in 2030 also the increase in shrimp farming area is going to badly affect the agricultural land and the Desopran block (1683.07 h) will experience the highest loss in agricultural land followed by Contai-III (515.30 ha), Contai-I (445.62 ha), Ramnagar-II (213.18 h), Ramnagar-I (126.23 ha) accordingly. This prediction gives a great threat to sustainability, and especially for the agricultural area which is a key source to enhance the socio-economic condition of the coastal village areas.

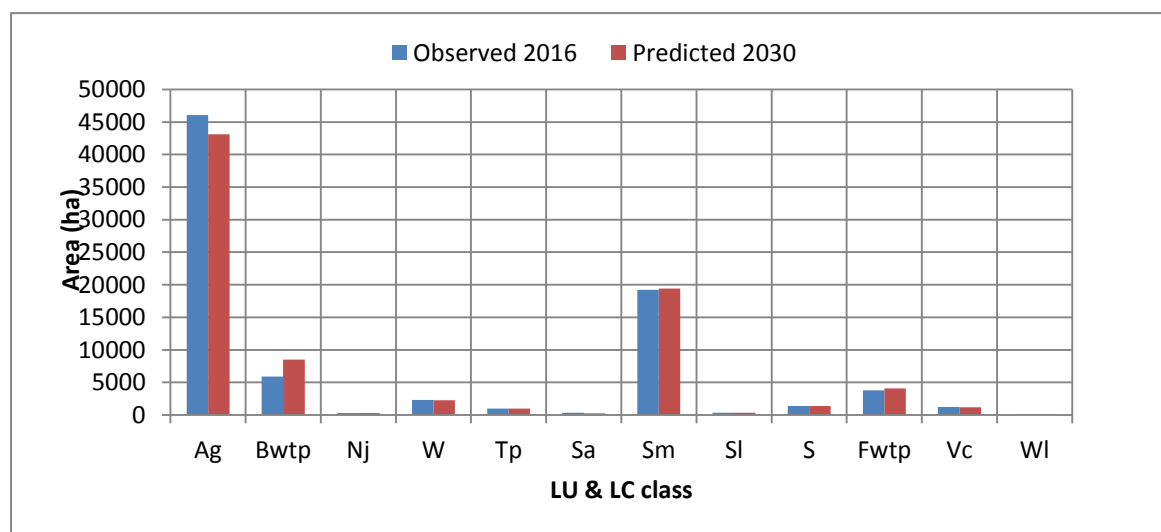

Figure 5.15 Comparison between observed Land use and Land cover (2016) and predicted Land use and Land cover (2030)



## 5.4 Summary

Detailed and accurate LU and LC data has been obtained through multi-temporal satellite data analysis. By image differencing and classification comparison method, not only detailed statistics of LU and LC changes of the study area are obtained but also the human activities of the study area are also recognized.

Coastal aquaculture activity has been noticed in the study area for a long time and this aquaculture is done by following traditional procedures. Aquaculture by traditional procedures was limited to coastal saline lowland areas. However, in the last two decades, continuous development in coastal aquaculture is observed. This development has introduced many positive and negative impacts on coastal areas but the extreme consequences of negative impact are faced by agricultural land. The reasons behind this are loss/limited profit from rice cultivation. The focus of the Government has also moved to aquaculture and people are encouraged to do more and more aquaculture to maximize the profit. In the year 2008, the total shrimp farming area was 4,234.13 ha (in study area) which has increased to 5,895.40 ha in the year 2016. Where the total number of brackish water tanks/ponds was 11,216 in the year 2008 and in the year 2016 it has increased to 21,104. In this timespan, not only shrimp farming area has increased but also a rise in fresh water tanks/ponds has been seen. The fresh water tanks/ponds covered 3675.18 ha area in 2008 and in 2016 it is also increased to 3795.21 ha. Traditional aquaculture is still available in Ramnagar-I and Ramnagar-II and the growth rate of aquaculture is also comparatively low in these areas. The maximum possible aquaculture has already done in these two areas before this survey/study has been initiated. These areas have adopted the advanced techniques of aquaculture but it is limited because most areas are already done following traditional techniques. Still, as a positive impact of new techniques, the area of aquaculture has been increased by 70 ha in Ramnagar-I and 113 ha in Ramnagar-II. Diasporan block (Contai-II) of the study area has experienced highest positive impact and the aquaculture area has increased by 1042.97 ha followed by Contai-III and Contai-I which are increased by 271.81 ha and 163.37 ha respectively. All these changes have been noticed from the year 2008 to 2016. In Contai-I both traditional and advanced shrimp farming are seen. In Desopran block and Contai-III block the shrimp farming is mainly done using advanced techniques. A noticeable increase in aquaculture is observed after the conversion of agricultural land

to brackish water tanks/ponds in these two areas. River/stream/canals are also affected and have used for aquaculture. In Ramnagar-I, Ramnagar-II and Contai-I, the increase in aquaculture are seen after conversion of sandy areas and scrublands to brackish water tanks/ponds. Some areas of agricultural land are also converted. Apart from the mentioned areas, freshwater tanks/ponds are affected and gone through some changes and have contributed to aquaculture. The LU and LC change prediction made with the help of Markov Chain for the year 2030, has also pointed the same tradition of increase in aquaculture land and settlement area and a decrease in agricultural land area. Referring to LU and LC change detection and future LU and LC prediction for the year 2030, it is seen that there is a great increase in aquaculture and hence observed a huge impact on the economy. But this growing condition of coastal aquaculture activities in the study area is always indicating a threat to natural and environmental conditions.