

Numerical Investigation of Three-Dimensional Interaction Turbulent Flow

Md. Rakibul Hasan^a and K.M Ariful Kabir^b

^aDepartment of Computer Science and Engineering, Southeast University
Dhaka-1213, Bangladesh

E-mail: md.rakibul_hasan@yahoo.com

^bDepartment Mathematics, Bangladesh University of Engineering and Technology
Dhaka-1000, Bangladesh

E-mail: k.ariful@yahoo.com

Received 13 June 2017; accepted 2 August 2017

ABSTRACT

The turbulent flow of water around a submarine has been studied numerically. The application of Computational Fluid Dynamics (CFD) to the maritime engineering is increasing day by day. A standard submarine body, pod and underwater vehicle hull forms are investigated. Three-dimensional Finite Element Method (FEM) has been applied to solve fluid structure interaction problem. Furthermore, standard k- ϵ is used to determine the contact properties and behavior of submarine under sea water to turbulent flow. The numerical results in terms of the skin friction, pressure and drag have been revealed. Moreover, velocity profiles as well as contour of pressure distribution have also been exhibited. The computed results display good agreement with the experimental and numerical results obtained by other researchers.

Keywords: Submarine, Computational Fluid Dynamics, Fluid Structure Interaction, Turbulent Fluid Flow, Finite Element Method.

1. Introduction

Computational Fluid Dynamics (CFD) is one of the tools of fluid mechanics that uses numerical methods to solve and analysis problems that oriented fluid flows. CFD has the power to model fluid flow and heat transfer in a profusion of situations. Now a day CFD is come to the forefront as a legitimate and effective research tool. Fluid structure interaction occurs when a fluid interacts with a solid structure, creating pressure that may cause deformation in the structure and, thus, alter the flow of the fluid itself. In Naval Architecture, Offshore and Ocean engineering, Fluid Structure Interaction (FSI) is one of the main areas for research. The ability to predict accurately fluid structure interaction is of fundamental importance for design, analysis and reconstruction in many areas of Naval Architecture and Ocean engineering.

According to the observation of Sumer [1], the flow field over the circular cylinder is symmetric at low values of Reynolds number. As the Reynolds number increases, flow begins to detach behind the cylinder causing vortex peeling which is an unsteady occurrence. There is a laminar vortex peeling in the wake of the cylinder for the $40 < Re < 200$. The laminar wake transient to turbulence in the region of $Re = 200$ to

300. In the subcritical region $300 < Re < 3 \times 10^5$ the wake behind the circular cylinder becomes completely turbulent and a laminar boundary layer parting occurs. The unsteady flow was first studied by Payne [2] for Reynolds number equal to 40 & 100. Braza *et al.* [3] and [4] observed the numerical study and physical inquiry of the pressure and velocity fields in the near wake of a circular cylinder for laminar and turbulent flow. Recently Lakshmipathy [5] and Rahman *et al.* [6] have also studied this problem for various Reynolds numbers. Most of the experimental studies examined the steady and unsteady behaviours of the alternating vortices in the wake. Christopher Baker [7], estimating drag forces on defence research establishment atlantic bare submarine hull using CFD. The tentative examination of Tritton [8] and Anderson [9] should be mentioned. A considerable amount of research work has been published on flow around the axisymmetric and 2 & 3 dimensionals body of revolution such as; sphere, pod, submarine, axisymmetric under-water body etc. The basic structure of the flow past a sphere has been experimentally investigated using a variety of methods, including flow visualization by Kim [10], Sakamoto [11] etc. Recent time-dependent computations of laminar and turbulent flow around spheres using different methods are reported by many researchers, among them the work of Kalro [12], and Sun *et al.*[13] are remarkable. Various researchers tried to simulate flow around bodies since late seventies by turbulence modelling. Patel and Chen [14] made a widespread analysis of the simulation of flow past axisymmetric bodies. Choi and Chen [15] gave numerical solution of RANS equation, together with k- ϵ turbulence model. Sarkar et al. [16] used a low-Re k- ϵ model for simulation of flow past underwater axisymmetric bodies. In this research, RANS standard k- ϵ model is used to simulate three-dimensional turbulent flow past underwater submarine hull forms. The main objective of the present study is to apply Finite Element Method for the turbulent analysis of fluid structure interaction. The investigation is carried out to simulate incompressible flow around submarine and investigate the viscous drag and flow pattern.

2. Model description and mathematical formulation

2.1. Model description

In the present study, a typical submarine hull is modeled and simulated using three dimensional CFD (Computational Fluid Dynamics). The net length is 32m, width 5m, height 5m and sail 1m of the submarine. Dimension of the box is 50*20*20 m³, shown in Figure 1 and Figure 2 respectively. Here we use open boundary for box, west face as an inlet with 5m/s velocity and east face as an outlet in this study. High resolution second order accurate advection scheme was used to discretize the equations for the flow, turbulent kinetic energy and turbulence eddy dissipation. Kajtar et al [17], simulated different cases using Flovent by employing $\epsilon - k$ turbulence model. The CFD module is the platform for simulating devices and systems that involve sophisticated fluid flow. Initially we use 0 (zero) velocity. An unstructured triangular shape grid is adopted for the entire domain for meshing which consists of 3776253 domain elements, 76666 boundary elements, and 2050 edge elements. It is ensured that the computation domain and the number of grids are sufficient enough to calculate the drag on the body accurately.

Numerical Investigation of Three-Dimensional Interaction Turbulent Flow

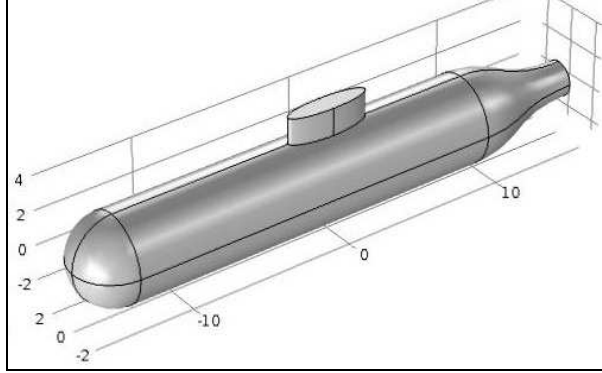

Figure 1: 3D Geometry of Submarine Hull

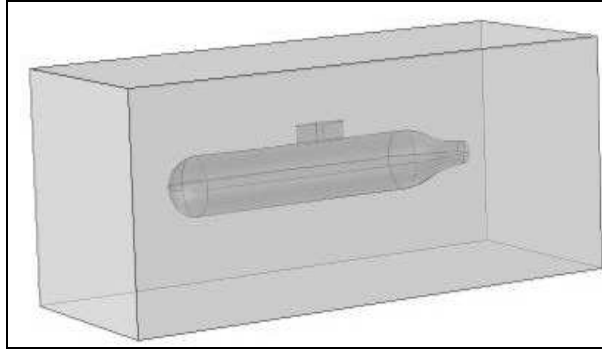

Figure 2: 3D Geometry of present study for Submarine Hull

2.2. Mathematical formulation

The problem is solved using a set of equation for incompressible, unsteady fluid flow with standard $k - \epsilon$ model. The incompressible Navier-Stokes equations in conservation form are [19],

$$\rho \nabla \mathbf{u} = \mathbf{0} \quad (1)$$

Also momentum equations are given by,

$$\rho \frac{\partial \mathbf{u}}{\partial t} + \rho (\mathbf{u} \cdot \nabla) \mathbf{u} = \nabla \cdot [-p\mathbf{I} + (\mu + \mu_T)(\nabla \mathbf{u} + (\nabla \mathbf{u})^T)] + \mathbf{F} \quad (2)$$

The standard $k - \epsilon$ model is a semi-empirical model based on model transport equations for the turbulence kinetic energy k and its dissipation rate ϵ . The model transport equation for k is derived from the exact equation, while the model transport equation for ϵ was obtained using physical reasoning and bears little resemblance to its mathematically exact counterpart. In the derivation of the $k - \epsilon$ model, it was assumed that the flow is fully turbulent, and the effects of molecular viscosity are negligible. The standard $k - \epsilon$ model is therefore valid only for fully turbulent flows.

$$\text{Kinetic eddy viscosity: } \mu_T = \rho C_\mu \left(\frac{k^2}{\epsilon} \right) \quad (3)$$

$$\text{Turbulence Kinetic Energy: } \rho \frac{\partial k}{\partial t} + \rho (\mathbf{u} \cdot \nabla) k = \nabla \cdot \left[\left(\mu + \frac{\mu_T}{\sigma_k} \right) \cdot \nabla k \right] + p_k - \rho \epsilon \quad (4)$$

$$\text{Specific Dissipation rate: } \rho \frac{\partial \epsilon}{\partial t} + \rho (\mathbf{u} \cdot \nabla) \epsilon = \nabla \cdot \left[\left(\mu + \frac{\mu_T}{\sigma_\epsilon} \right) \cdot \nabla \epsilon \right] + C_{\epsilon 1} \frac{\epsilon}{k} p_k - C_{\epsilon 2} \frac{\epsilon^2}{k} \rho \quad (5)$$

Where $p_k = \mu_T (\nabla \mathbf{u} + (\nabla \mathbf{u})^T)$

Md.Rakibul Hasan and K.M Ariful Kabir

Closure Coefficients and Relations: $C_{\epsilon_1} = 1.44, C_{\epsilon_2} = 1.92, C_{\mu} = 0.09, \sigma_k = 1, \sigma_{\epsilon} = 1.3,$
 For wall function: $\mathbf{u} \cdot \mathbf{n} = 0, [(\mu + \mu_T)(\nabla \mathbf{u} + (\nabla \mathbf{u})^T)] \cdot \mathbf{n} = -\rho \frac{u_{\tau}}{\sigma_W} u_{\text{rang}}$ (6)

Where $u_{\text{rang}} = \mathbf{u} - (\mathbf{u} \cdot \mathbf{n})\mathbf{n}$ and $\nabla_k \cdot \mathbf{n} = 0, \epsilon = \rho \frac{C_{\mu} k^2}{k_{\tau} \sigma_W \mu}$

3. Result and discussion

The submerged body used in this research is a standard submarine bare hull. Standard k- ω model is used for capturing turbulent flow. The flow is simulated at high Reynolds number. Numerical analysis based on finite element method is used to solve three dimensional unsteady flows in enclosed space and resulting flow velocity field. Velocity magnitude is shown for different times between 0.5s and 20s in Figure 3. Figure 3

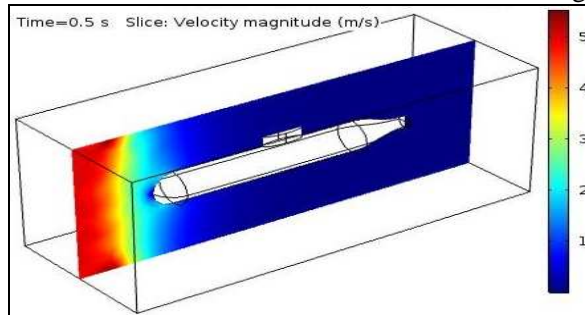

Figure 3(a): Velocity Magnitude for 0.5 S

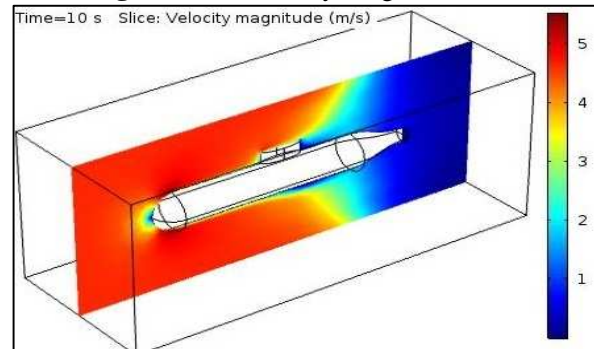

Figure 3(B): Velocity Magnitude for 10 S

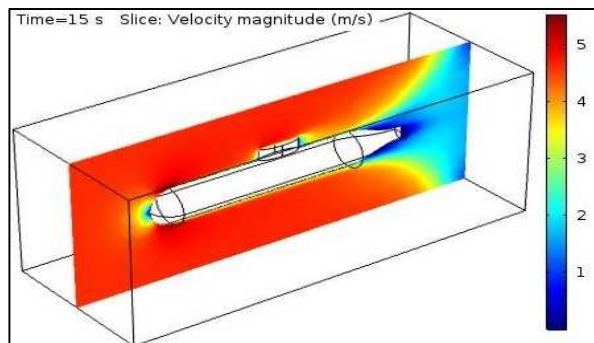

Figure 3(C): Velocity Magnitude For 15 S

Numerical Investigation of Three-Dimensional Interaction Turbulent Flow

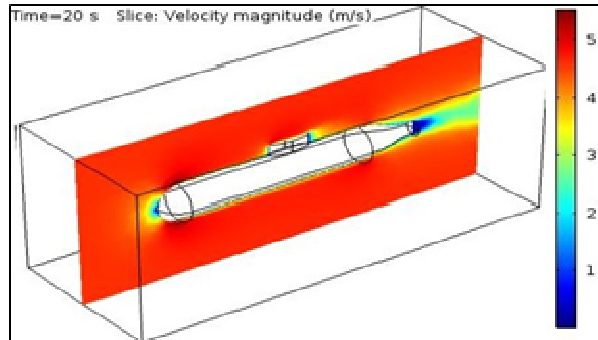

Figure 3(D): Velocity Magnitude For 20 S

shows the velocity magnitude for the submarine hull using unstructured grid. When compared to the pressure plot it can be seen that the stagnation point of high pressure corresponds to the low velocity point at the front, the favorable pressure gradient in the

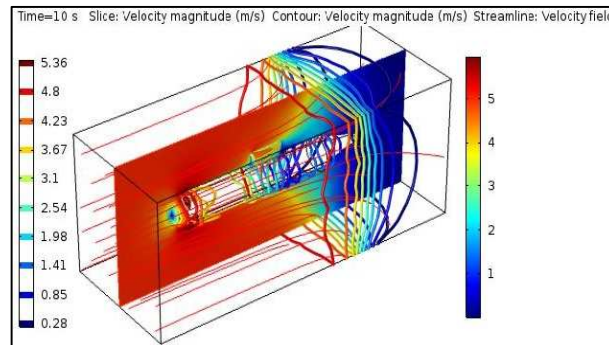

Figure 4 (a): velocity magnitude with stream line and contour. (Left legend for contour and right legend for velocity magnitude)

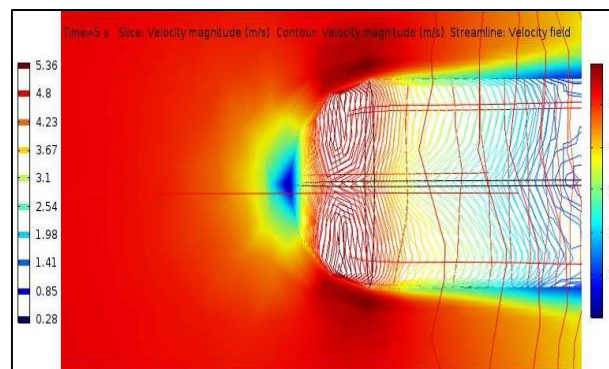

Figure 4 (b): Zooming View of the Contours and stream line of velocity magnitude of Submarine Hull

front section corresponds to a high velocity and the adverse pressure gradient at the rear corresponds to a lower velocity shown in Figure 4 (a). Figure 4 (b) shows a close up view

of the front section of the velocity profile. In this paper, it is apparent by the colors close to the shape that the no slip boundary condition set for the surface of the hull is in effect. It is also more apparent that the stagnation point is actually a point with zero velocity. The contour of static pressure around the submarine hull using unstructured grid is shown in Figure 5. The stagnation point of high pressure at the front tip of the hull, the favorable pressure gradient at the front section and the adverse pressure gradient at the rear section of the hull are clearly shown. Since the reference pressure is set to zero the pressures shown are relative.

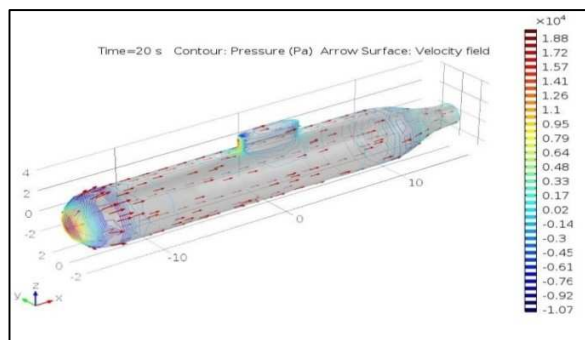

Figure 5(a): Contours of Static Pressure for Submarine Bare Hull.

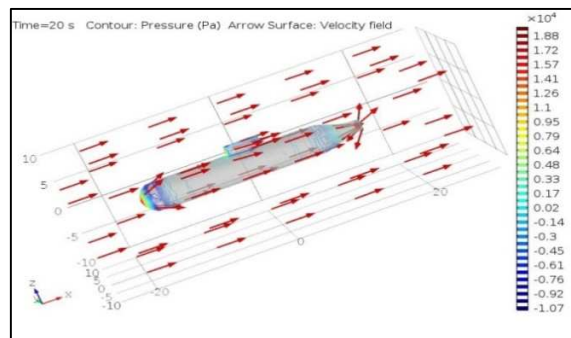

Figure 5 (b): Contours of Static Pressure for Submarine Bare Hull.

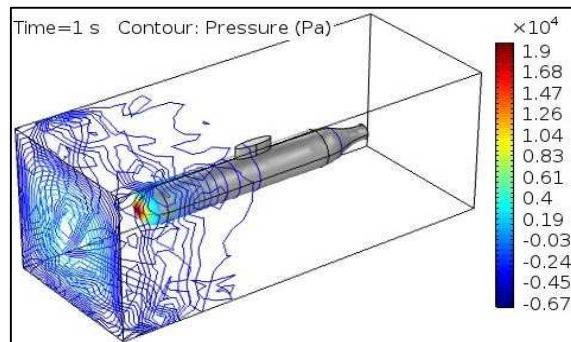

Figure 6 (a): Contour pressure at 1s.

Numerical Investigation of Three-Dimensional Interaction Turbulent Flow

Figure 6 (a), Figure 6 (b) and Figure 6 (c) show contour pressure for different times. Figure 6 (d) displays contour pressure with stream line velocity field at 20s. Figure 7(a) and Figure 7 (b) shows a close up of the front and back section of the

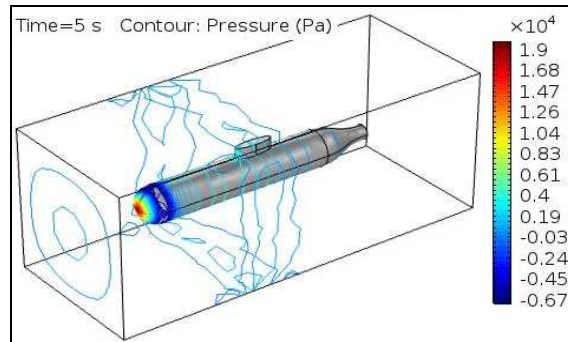

Figure 6(b): Contour Pressure At 5s

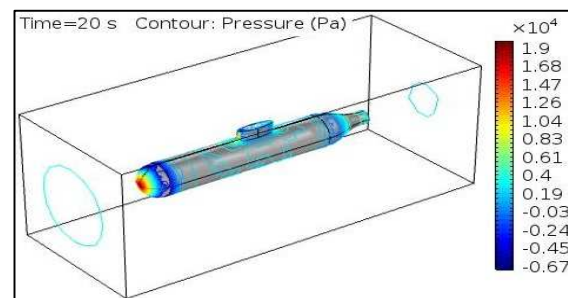

Figure 6 (c): Contour pressure with stream line velocity field at 20s.

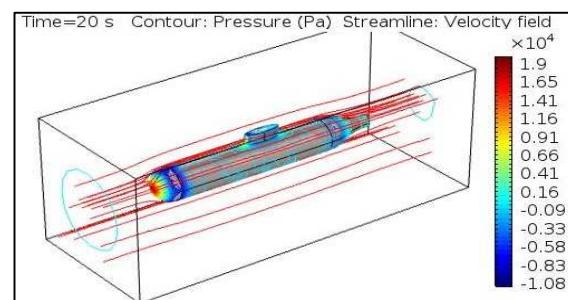

Figure 6 (d): Contour pressure with stream line velocity field at 20s

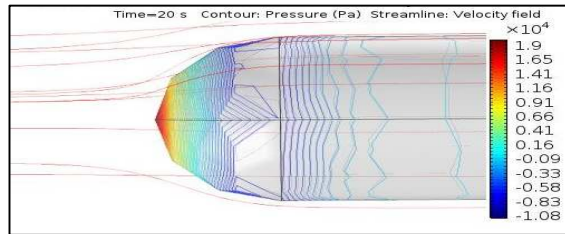

Figure 7(a): Zooming view of front side.

hull. Here the stagnation point and the favorable pressure gradient are even more visible. The wall shear plot is a good indication of the viscous drag over the hull surface. It can also be used to check if there is any separation because the wall shear goes to zero where the boundary layer separates. Viscous effect occurred only on the boundary surface of the body shown for different time in Figure 8. It shows a large wall shear affect in the favorable pressure gradient area at the front section of the hull. The very peak of the front

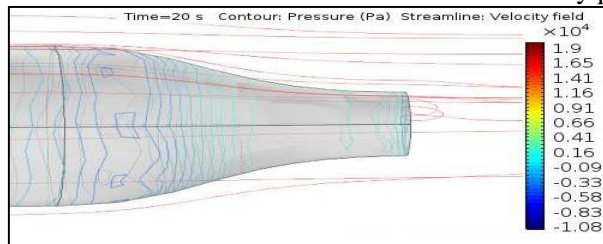

Figure 7 (b): Zooming view of back side.

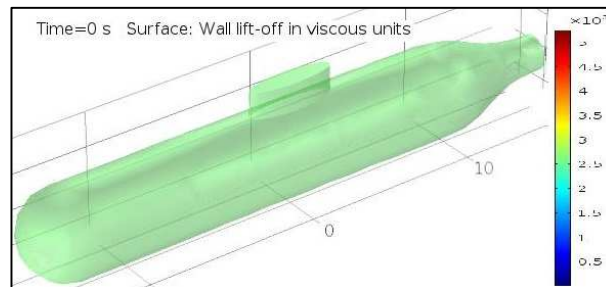

Figure 8(a): Viscous effect occurred on the boundary for 0 s

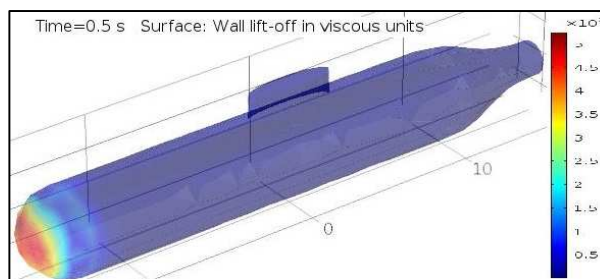

Figure 8(b): Viscous effect occurred on the boundary for 0.5 second

Numerical Investigation of Three-Dimensional Interaction Turbulent Flow

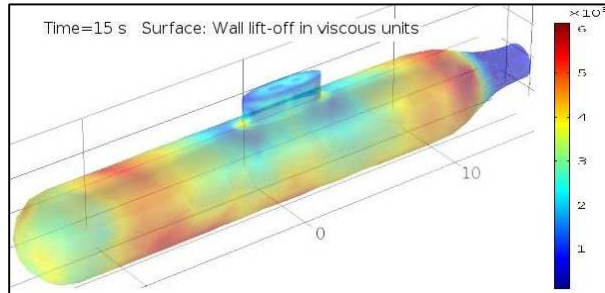

Figure 8(c): Viscous effect occurred on the boundary for 15 s

section has a reduced wall shear, which makes sense physically because there is a reduced flow velocity in this region due to the stagnation point. This illustrates how this region largely affects the viscous losses. This Figure also shows the boundary surface region closer, which indicates a high shear stress.

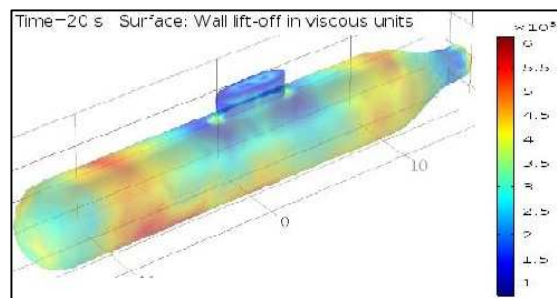

Figure 8(d): Viscous effect occurred on the boundary for 20 s

4. Conclusion

The Numerical investigation was studied at modeling flow around a submarine hull. Mathematical examination of flow around underwater vehicle was performed in this research using finite element method based on Reynolds averaged Navier-Stokes equations. Though the result of the study was satisfactory, results obtained through this study are not explained all the condition and possibility. Through analysis, calculations can be drawn as follows:

The overall project was successful at modeling flow around submarine hull. Numerical computation of flow around underwater vehicle is performed in this research using finite element method based on Reynolds averaged Navier-Stokes equations. Standard $k-\omega$ model has been used to simulate fully turbulent flow past 3dimensional underwater body. Unstructured grids are studied in this research. The computed results show well agreement with published experimental measurements. Though the result of the study was satisfactory, results obtained through this study are not explained all the condition and possibility. Through analysis, calculations can be drawn as follows:

- To save energy and making sustained deign.
- Different types and shapes of underwater vehicles would be easily verify and testify by using this numerical simulation.

Md.Rakibul Hasan and K.M Ariful Kabir

- It is observed that underwater vehicle can be designed by using this computational method to optimize cost and materials.
- To build appropriate underwater vehicle in a specific reason or condition, this model should be helpful and time saving.

REFERENCES

1. B.M.Sumer, Hydrodynamics around Cylindrical Structures, World Scientific, Singapore, 1997.
2. R.B.Payne, Calculations of Unsteady Viscous Flow past a Circular Cylinder, J. Fluid Mech., 4 (1958) 81.
3. M.Braza, P.Chassaing and H.H.Minh, The Numerical Study and Physical Analysis of the Pressure and velocity Fields in the Near Wake of a Circular Cylinder, J. Fluid Mech., 165 (1986) 79.
4. M.Braza, P.Chassaing and H.H.Minh, Prediction of Large-Scale Transition features in the wake of a Circular Cylinder, Phys. Fluids, A2 (1990) 1461-1471.
5. S.Lakshmipathy, PANS Method for Turbulence Simulation of High and Low Reynolds Number Flow Past a Circular Cylinder, M. Sc. Thesis, Dept. of Aerospace Eng. Texas A. & M. University, USA, 2004.
6. M.M.Rahman, M.M.Karim and M.A.Alim M, Numerical Investigation of Unsteady Flow past a Circular Cylinder using 2-D Finite Volume method, Journal of Naval Architecture and Marine Engineering, 4 (2007) 27-42.
7. C.Baker, Estimating Drag Forces on Submarine Hulls, Defence R&D Canada – Atlantic, Contract Report DRDC Atlantic CR 2004-125 September 2004.
8. D.J.Tritton, Experiments on the Flow around a Circular Cylinder at Low Reynolds Number, J. Fluid Mech., 6 (1959) 547.
9. J.D.Anderson, Fundamentals of Aerodynamics, 4th Ed., Mc Grow-Hill, Columbus, USA, 2005.
10. H.J.Kim and P.A.Durbin, Observations of the Frequencies in a Sphere Wake and of Drag Increase by Acoustic Xcitation, Physics of Fluids, 31(1988) 3260–3265.
11. H.Sakamoto and H.Haniu, A Study of Vortex Shedding from Spheres in a Uniform Flow, Journal of Fluids Engineering, 112 (1990) 386–392.
12. V.Kalro and T.Tezduyan, 3D Computation of Unsteady Flow past a Sphere with a Parallel Finite Element Method, Computer Methods in Applied Mechanics and Engineering, 151 (1998) 267–276.
13. R.Sun and T.A.Chwang, Hydrodynamic Interaction between a Prolate Spheroid and a Sphere, Structural Control Health Monitoring, 13 (2006) 147–168.
14. V.C.Patel and H.C.Chen, Flow over Tail and in Wake of Axisymmetric Bodies: Review of The State of The Art, Journal of Ship Research, 30 (1986) 202-314.
15. S.K.Choi and C.J.Chen, Laminar and Turbulent Flows Past Two Dimensional and Axisymmetric Bodies, Iowa Institute of Hydraulic Research, IIHR Report 334-II, 1990.
16. T.Sarkar, P.G.Sayer and S.M.Fraser, A Study of Autonomous Underwater Vehicle Hull Forms Using Computational Fluid Dynamics, International Journal for Numerical Methods in Fluids, 25 (1997) 1301-1313.

Numerical Investigation of Three-Dimensional Interaction Turbulent Flow

17. L.Kajtar and A.Leitner, CFD Modelling of Indoor Air Quality and Thermal Comfort, Proceedings of the 2nd IASME / WSEAS International Conference on Continuum Mechanics (CM'07), Portoroz, Slovenia, May 15-17, 2007.
18. Department of Research and Development Canada- Atlantic, National Defense, "Fall 1988 Wind Tunnel Test of the DREA Six Meter Long Submarine Model- Force Data Analysis", Ottawa.
19. H.K.Versteeg and W.Malalasekera, An Introduction to Computational Fluid Dynamics, Pearson Prentice Hall, Toronto, 1995.